

Ruijie Reyee RG-RAP6260(H) Access Point

Hardware Installation and Reference Guide



Copyright

Copyright © 2022 Ruijie Networks

All rights are reserved in this document and this statement.

Any reproduction, excerpt, backup, modification, transmission, translation or commercial use of this document or any portion of this document, in any form or by any means, without the prior written consent of Ruijie Networks is prohibited.

Trademarks including  are owned by Ruijie Networks.

All other trademarks or registered trademarks mentioned in this document are owned by their respective owners.

Disclaimer

The products, services, or features you purchase are subject to commercial contracts and terms. Some or all of the products, services or features described in this document may not be within the scope of your purchase or use. Unless otherwise agreed in the contract, Ruijie Networks does not make any express or implied statement or guarantee for the content of this document.

Due to product version upgrades or other reasons, the content of this document will be updated from time to time. Ruijie Networks reserves the right to modify the content of the document without any notice or prompt.

This manual is for reference only. Ruijie Networks endeavors to ensure content accuracy and will not shoulder any responsibility for losses and damages caused due to content omissions, inaccuracies or errors.

Preface

Intended Audience

This document is intended for:

- Network engineers
- Technical support and servicing engineers
- Network administrators

Technical Support

- Official website of Ruijie Reye: <https://www.ruijienetworks.com/products/reeye>
- Technical Support Website: <https://ruijienetworks.com/support>
- Case Portal: <https://caseportal.ruijienetworks.com>
- Community: <https://community.ruijienetworks.com>
- Technical Support Email: service_rj@ruijienetworks.com

Conventions

1. GUI Symbols

Interface symbol	Description	Example
Boldface	1. Button names 2. Window names, tab name, field name and menu items 3. Link	1. Click OK . 2. Select Config Wizard . 3. Click the Download File link.
>	Multi-level menus items	Select System > Time .

2. Signs

The signs used in this document are described as follows:

Warning

An alert that calls attention to important rules and information that if not understood or followed can result in data loss or equipment damage.

Caution

An alert that calls attention to essential information that if not understood or followed can result in function failure or performance degradation.

Note

An alert that contains additional or supplementary information that if not understood or followed will not lead to serious consequences.

 **Specification**

An alert that contains a description of product or version support.

3. Note

This manual provides the device installation steps, hardware troubleshooting, module technical specifications, and specifications and usage guidelines for cables and connectors. It is intended for the users who have some experience in installing and maintaining network hardware. At the same time, it is assumed that the users are already familiar with the related terms and concepts.

Contents

Preface	1
1 Product Overview	1
1.1 About the RG-RAP6260(H) Access Point	1
1.2 Package Contents.....	1
1.3 Hardware Features	2
1.3.1 Access Point.....	2
1.3.2 Ports and LED.....	3
1.3.3 RESET Hole.....	4
1.4 Technical Specifications	4
1.5 Power Specifications	6
1.6 Heat Dissipation.....	7
2 Preparing for Installation	8
2.1 Safety Precautions.....	8
2.1.1 General Safety Precautions.....	8
2.1.2 Handling Safety.....	8
2.1.3 Electric Safety	8
2.1.4 Laser Safety	9
2.2 Installation Environment Requirements.....	9
2.2.1 Bearing Requirements	9
2.2.2 Ventilation Requirements.....	9
2.2.3 Temperature/Humidity Requirements	9
2.2.4 Waterproof Requirement.....	10
2.2.5 Grounding Requirement	10

2.2.6 Anti-interference Requirements	10
2.3 Tools	10
3 Installing the Access Point	11
3.1 Installation Procedure	11
3.2 Before You Begin.....	11
3.3 Precautions	12
3.4 Installing the Access Point.....	12
3.4.1 Installing the Mounting Arm	12
3.4.2 Wall Mounting	14
3.4.3 Vertical Pole Mounting	15
3.4.4 Horizontal Pole Mounting.....	16
3.4.5 Adjusting Orientation.....	17
3.5 Installing the Cable	17
3.5.1 Installing the Ethernet Cable.....	17
3.5.2 Installing the Grounding Cable	18
3.6 Bundling Cables.....	18
3.6.1 Precautions	18
3.6.2 Steps	19
3.7 Checking After Installation	19
4 Verifying Operating Status	20
4.1 Setting up Configuration Environment.....	20
4.2 Powering on the Access Point.....	20
4.2.1 Checklist Before Power-on	20
4.2.2 Checklist After Power-on	20

5 Monitoring and Maintenance.....	21
5.1 Monitoring	21
5.2 Hardware Maintenance.....	21
6 Common Troubleshooting.....	22
6.1 General Troubleshooting Procedure	22
6.2 Common Faults.....	22
7 Appendix.....	23
7.1 Connectors and Media.....	23
7.1.1 2500BASE-T/1000BASE-T/100BASE-TX/10BASE-T Port	23
7.1.2 Fiber-Optic Cable Connection	24
7.2 Mini-GBIC Modules.....	25
7.3 Cabling.....	27

1 Product Overview

1.1 About the RG-RAP6260(H) Access Point

The RG-RAP6260(H) is a dual-radio access point designed to cover a medium or large outdoor area. Compliant with the IEEE 802.11a/b/g/n/ac/ax standard, the access point can work at the 2.4 GHz and 5 GHz bands at the same time and supports quad-stream MU-MIMO. The access point provides a combined data rate of 5952 Mbps, with up to 1148 Mbps in the 2.4 GHz band and 4804 Mbps in the 5 GHz band. The access point provides one 2.5GE copper port and one GE fiber port. The copper port adopts either IEEE 802.3bt PoE power supply or 48 V DC local power supply.

The enclosure of RG-RAP6260(H) meets the IP68 protection grade, which withstands the extreme outdoor environment and can effectively avoid the influence of bad weather and environment. The mounting method greatly simplifies the installation and maintenance.

RG-RAP6260(H) supports PoE and can be applied to a wide variety of outdoor scenarios in the sectors including higher education, government, health care, general education, finance and business.

1.2 Package Contents

Table 1-1 Package Contents

Item	Quantity
Access Point	1
Hose Clamp	2
Mounting Plate	1
M8 x 20 Screws	4
M8 x 60 Expansion Anchors	4
User Manual	1
Cable Gland for SFP Port	1
Cable Gland for Ethernet Port (Pre-installed on the access point)	1
SFP Port Plug (Pre-installed on the access point)	1
Mounting Arm	1
DC Connector Plug (Pre-installed on the access point)	1
Cable Gland for DC Connector	1
Grounding Cable	1

Note

- The package contents generally contain the above items. The actual delivery is subject to the order contract. And please check your goods carefully against the order contract. If you have any questions, please contact the distributor.

1.3 Hardware Features

1.3.1 Access Point

Figure 1-1 Access Point



1.3.2 Ports and LED

Figure 1-2 Ports and LED

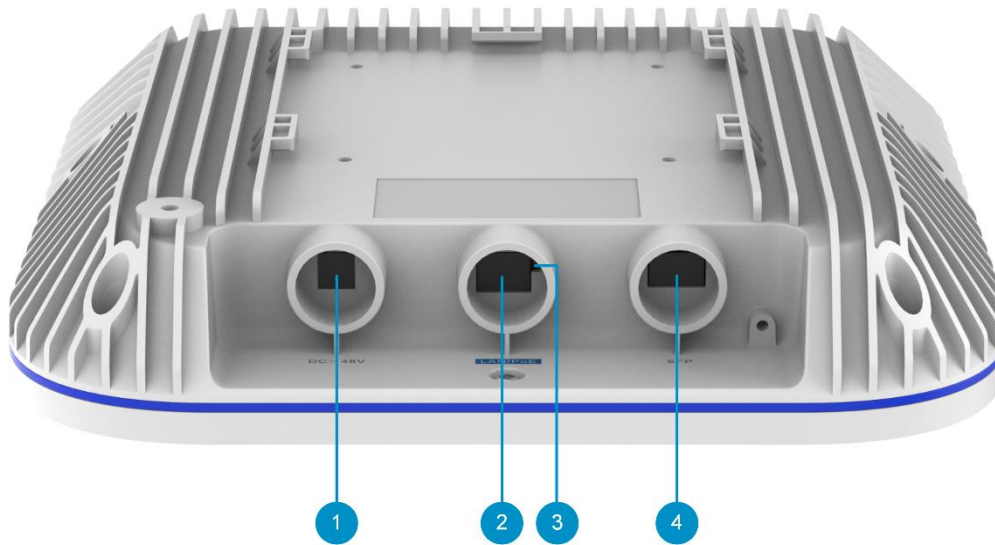

Table 1-1 Ports

No.	Ports	Description
1	DC Connector	48 V DC/1 A input
2	Ethernet/PoE Port	100/1000/2500Base-T Ethernet ports, PoE-capable
3	RESET Hole	The RESET hole is near the Ethernet/PoE port. <ul style="list-style-type: none"> ● Press and hold the pin to the RESET hole for less than 2 seconds: Restart the access point. ● Press and hold the pin to the RESET hole for between 2 to 5 seconds: There is no action on the access point. ● Press and hold the pin to the RESET hole for more than 5 seconds: Restore the access point to factory settings.
4	SFP Port	1000Base-X SFP port (The SFP transceiver is an optional accessory.)

Table 1-2 LED

Color	Status
Off	The access point is not receiving power.
Slow Blinking	The access point is operating normally but there is an alarm generated.
Fast Blinking	Possible cases: <ol style="list-style-type: none"> 1. Restoring the access point to factory settings. 2. Upgrading the firmware.

	<p>3. Handling alarms automatically.</p> <p>4. Starting up the access point.</p>
Solid Blue	The access point is operating normally with no alarms.

1.3.3 RESET Hole

- RG-RAP6260(H) supports cloud-based management. To reset the access point, you are advised to connect the access point to the Internet and perform reset on Ruijie Cloud.
- If it is inconvenient to connect to the Internet, insert a pin into the RESET hole as marked by red point. Press and hold the pin for over 5 seconds, and the access point will restore to factory settings.

Figure 1-3 RESET Hole

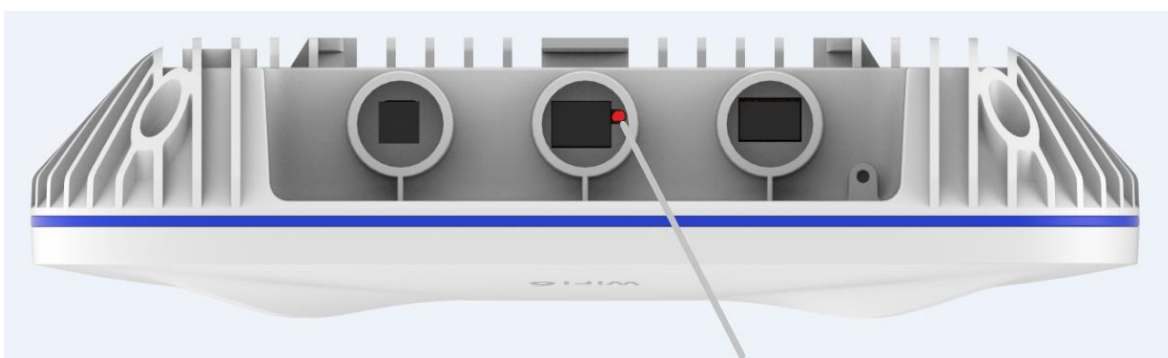

Warning

- You are advised to loosen the cable gland before using the RESET hole. Please see [Installing the Ethernet Cable](#) for details.

1.4 Technical Specifications

Table 1-3 Technical Specifications

Radio Design	Dual-radio, four spatial streams
Standard & Protocol	802.11ax, 802.11ac wave2/wave1 and 802.11a/b/g/n
Operating Radio	<p>802.11b/g/n/ax: 2.4 GHz to 2.4835 GHz</p> <p>802.11a/n/ac/ax: 5.150 GHz to 5.350 GHz, 5.470 GHz to 5.725 GHz, 5.725 GHz to 5.850 GHz</p> <p>Note: The operating radio is country-specific.</p>
Antenna	Built-in Antenna (2.4 GHz: 3 dBi; 5 GHz: 4 dBi)
Spatial Streams	<p>2.4 GHz: 4 x 4 MIMO</p> <p>5 GHz: 4 x 4 MIMO</p>
Max. Data Rate	<p>2.4 GHz: 1148 Mbps</p> <p>5 GHz: 4804 Mbps</p>

	Combined: 5952 Mbps
Modulation	OFDM: BPSK@6/9 Mbps, QPSK@12/18 Mbps, 16QAM@24 Mbps, 64QAM@48/54 Mbps DSSS: DBPSK@1 Mbps, DQPSK@2 Mbps, and CCK@5.5/11 Mbps MIMO-OFDM: BPSK, QPSK, 16QAM, 64QAM, 256QAM and 1024QAM OFDMA
Receive Sensitivity	11b: -96 dBm (1 Mbps), -93 dBm (5 Mbps), -89 dBm (11 Mbps) 11a/g: -91 dBm (6 Mbps), -85 dBm(24Mbps), -80 dBm (36 Mbps), -74 dBm (54 Mbps) 11n: -90 dBm (MCS0), -70 dBm (MCS7), -89 dBm (MCS8), -68 dBm (MCS15) 11ac: 20 MHz: -88 dBm (MCS0), -63 dBm (MCS9) 11ac: 40 MHz: -85 dBm (MCS0), -60 dBm (MCS9) 11ac: 80 MHz: -85 dBm (MCS0), -60 dBm (MCS9) 11ax: 80 MHz: -82 dBm (MCS0), -57 dBm (MCS9), -52 dBm (MCS11) 11ax: 160 MHz: -75 dBm (MCS0), -55 dBm (MCS9), -50 dBm (MCS11)
Max. Transmit Power	400 mw (26 dBm) Note: The transmit power is country-specific.
Power Adjustment	Configurable in increments of 1 dBm
Dimensions (W x D x H)	300 mm x 300 mm x 75.5 mm (11.81 in. x 11.81 in. x 2.97 in., without the mounting plate)
Weight	≤ 3.5 kg (7.72 lbs., without the mounting plate)
Service Ports	One 100/1000/2500Base-T Ethernet port, PoE-capable One 1000Base-X SFP port (The SFP transceiver is an optional accessory.) <hr/> i Note <ul style="list-style-type: none"> ● The access point itself does not transmit optical signals. You must install an optical transceiver module on the access point to convert optical signals into electrical signals.
Management Port	N/A
Status LED	One LED (blue)
Power Supply	There are three power supply modes available: <ul style="list-style-type: none"> ● Standard PoE: IEEE 802.3bt standard(PoE++), backward compatible with the IEEE 802.3at standard(PoE+) ● 60W Passive PoE adapter (Optional accessory) ● Local power supply: 48 V DC /1 A

	Note: The access point is not 802.3af-compliant. (See Power Specifications for power supply modes and respective data rate.)	
Max. Power Consumption	Local power supply: 48 V DC/1 A	40 W
	IEEE 802.3bt PoE power supply	
	60 W passive PoE power supply	
	IEEE 802.3at PoE power supply	25 W
Environment	Operating temperature: -40°C to 65°C (-40°F to 149°F)	
	Storage temperature: -40°C to 85°C (-40°F to 185°F)	
	Operating humidity: 0% to 100% RH (non-condensing)	
	Storage humidity: 0% to 100% RH (non-condensing)	
Mounting Method	Wall mounting and pole mounting	
	Recommended height: 2.5 m to 3 m (98.43 in. to 118.11 in.) above the ground	
Certification	CE	
MTBF	> 400000 hours	

⚠ Caution

- Operation of this equipment in a residential environment could cause radio interference.
-

1.5 Power Specifications

The access point can be powered by either PoE or DC power supply.

- In a PoE power supply scenario, the power source equipment (PSE) must be at least 802.3at-capable. You are advised to use an 802.3bt-capable PSE. If you want to use a PoE adapter, a Rujie-certificated PoE adapter is recommended.
- In a DC power supply scenario, use a 48 V DC/1 A power adapter with a 5.5 mm x 2.1 mm x 10 mm (0.22 in. x 0.08 in. x 0.39 in.) plug.

Table 1-4 Power Supply Mode

Power Input	Standard PoE: IEEE 802.3bt standard, backward compatible with the IEEE 802.3at standard			
	Local power supply: 48 V DC/1 A			
Power Supply Mode	2.4 GHz	5 GHz	Data Rate	Max. Power Consumption
IEEE 802.3bt Standard (Recommended)	4 x 4	4 x 4	5952 Mbps	40 W
60 W Passive PoE Adapter (Optional Accessory)	4 x 4	4 x 4	5952 Mbps	40 W
Local Power Supply (48 V DC /1 A)	4 x 4	4 x 4	5952 Mbps	40 W
IEEE 802.3at Standard	2 x 2	2 x 2	2976 Mbps	25 W

 **Warning**
The access point is not 802.3af-compliant.

1.6 Heat Dissipation

Maintain a sufficient clearance around the access point for proper ventilation.

2 Preparing for Installation

2.1 Safety Precautions

Note

- To avoid personal injury and device damage, carefully read the safety precautions before you install the access point.
 - The following safety precautions may not cover all possible hazardous situations.
-

2.1.1 General Safety Precautions

- Do not expose the access point to high temperature, dusts, or harmful gases. Do not install the AP in an inflammable or explosive environment. Keep the AP away from EMI sources such as large radar stations, radio stations, and substations. Do not subject the AP to unstable voltage, vibration, and noise.
 - Keep the access point at least 500 (0.31 miles) meters away from the ocean and do not face it towards the sea breeze.
 - The installation site should be free from water flooding, seepage, dripping, or condensation. The installation site should be selected according to network planning and communications equipment features, and considerations such as climate, hydrology, geology, earthquake, electrical power, and transportation.
 - Please make sure that the access point and power distribution system are properly grounded.
-

Caution

- Please follow the procedures in the user manual to install and remove the access point.
-

2.1.2 Handling Safety

- Do not move the access point frequently.
- Cut off all the power supplies and unplug all power cords before moving or handling the access point.

2.1.3 Electric Safety

Warning

- Improper or incorrect electric operations may cause a fire, electric shock, and other accidents, and lead to severe and fatal personal injury and device damage.
 - Direct or indirect contact with high voltage or mains power supply via wet objects may cause fatal dangers.
-
- Observe local regulations and specifications during electric operations. Only personnel with relevant qualifications can perform such operations.
 - Check whether there are potential risks in the work area. For example, check whether the power supply is grounded, whether the grounding is reliable, and whether the ground is wet.
 - Learn about the position of the indoor emergency power switch before installation. Cut off the power switch

in case of accidents.

- Check the access point carefully before shutting down the power supply.
- Keep the access point far away from grounding or lightning protection devices for power device.
- Keep the access point far away from radio stations, radar stations, high-frequency high-current devices, and microwave ovens.

2.1.4 Laser Safety

The SFP transceiver (optional accessory) is a class A laser product.

- When an SFP transceiver works, ensure that the port has been connected with a fiber-optic cable or sealed by a plug to keep out dust and prevent it from hurting your eyes.
- Do not stare at any fiber port.

 **Note**

- Do not approach or stare at any fiber port under any circumstances, as this may cause permanent damage to your eyes.
-

2.2 Installation Environment Requirements

For normal operation and prolonged service life of the access point, the installation site must meet the following requirements:

2.2.1 Bearing Requirements

Evaluate the weight of the access point and its accessories, and ensure that the installation site (wall or pole) can bear the weight.

2.2.2 Ventilation Requirements

The access point adopts natural cooling. Reserve a sufficient clearance around the access point to ensure proper ventilation.

2.2.3 Temperature/Humidity Requirements

To ensure the normal operation and prolonged service life of the access point, maintain an appropriate temperature and humidity. Working in an environment with too high or too low temperature and humidity for a long period may damage the access point.

- In an environment with high relative humidity, the insulating material may have poor insulation or even leak electricity. Sometimes it is also prone to changes in the mechanical properties and causes rusting of metal parts.
- In an environment with low relative humidity, static electricity is prone to occur and damage the internal circuits of the access point.
- A high temperature can accelerate the aging process of insulation materials, greatly reducing the reliability of the access point and severely affecting its service life.
- Before using the GE SFP transceiver (Mini-GBIC module), make sure that the ambient temperature meets

the requirement.

Table 2-1 Working Environment Requirements

Operating Temperature	Operating Humidity
-40°C to 65°C (-40°F to 149°F)	0% to 100% RH (non-condensing)

2.2.4 Waterproof Requirement

- Seal the unused ports using the connector plugs or cable glands to ensure that the access point is watertight.
- The cable glands must be used for all cables that are threaded through the ports to prevent exposing the access point interior to environmental elements. See [Installing the Ethernet Cable](#) for details.

2.2.5 Grounding Requirement

A proper grounding system is the basis for stable and reliable running and is indispensable for preventing lightning strikes and interference. Carefully check the grounding conditions at the installation site according to the grounding specifications, and complete grounding properly based on the actual situation.

2.2.6 Anti-interference Requirements

- Keep the access point as far away from the lightning prevention equipment and grounding equipment of the power device as possible.
- Keep the access point far away from radio stations, radar stations, high-frequency high-current devices, and microwave ovens.

2.3 Tools

Table 2-2 Tools

Common Tools	Phillips screwdriver, Hex screwdriver, power cords, Ethernet cables, fastening bolts, diagonal plier, and binding straps
Special Tools	Anti-static wrist strip, wire stripper, crimping plier, wire cutter, waterproof tape
Meters	Multimeter
Other Tools	PC, display, and keyboard

Note

The tool kit is not included in the package contents. The tool kit is customer-supplied.

3 Installing the Access Point

⚠ Caution

Before installing the access point, make sure you have carefully read the requirements in Chapter 2.

3.1 Installation Procedure

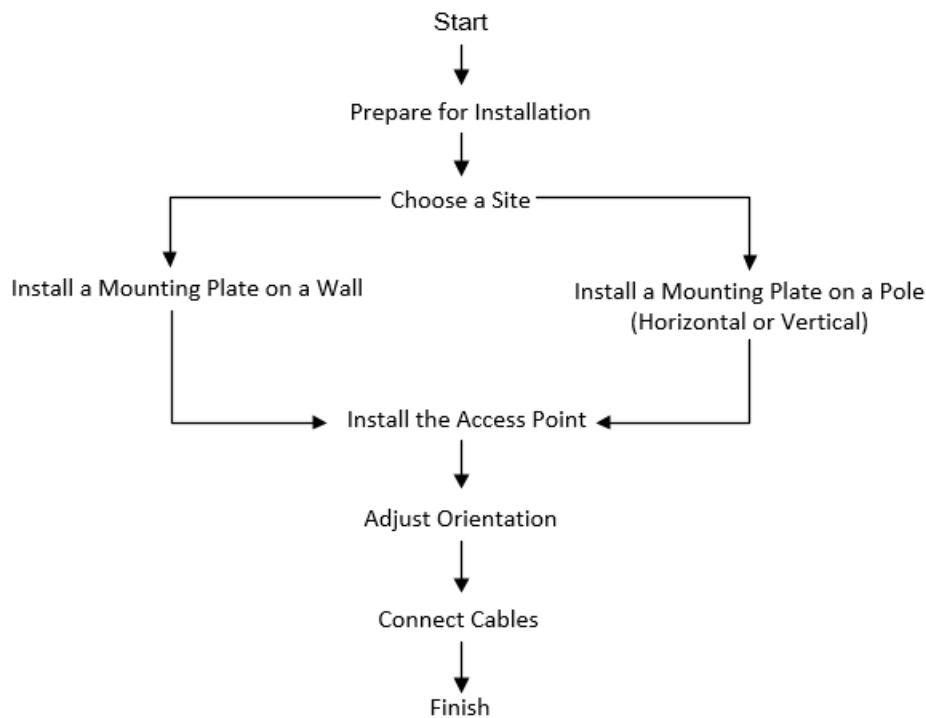

3.2 Before You Begin

Carefully plan and arrange the installation position, networking mode, power supply, and cabling before installation. Confirm the following requirements before installation:

- The installation site provides sufficient space for proper ventilation.
- The installation site meets the temperature and humidity requirements of the access point.
- The power supply and required current are available in the installation site.
- The selected power supply modules meet the system power requirements.
- The installation site meets the cabling requirements of the access point.
- The installation site meets the site requirements of the access point.
- The customized access point meets the client-specific requirements.

3.3 Precautions

The outdoor access point can be mounted on a wall or a pole with a diameter ranging from 50 mm to 70 mm (1.97 in. to 2.76 in.). If the diameter of the pole is out of this range, please prepare a hose clamp that can hold the pole. The thickness of the hose clamp should be at least 2.5 mm (0.10 in.). The installation site is determined by the technical personnel who conducts a site survey.

Please make sure that the installation site meets with the following requirements in [Installation Environment Requirements](#) and observe the following precautions:

- Do not power on the access point during installation.
- Install the access point in a well-ventilated location.
- Do not subject the access point to high temperature.
- Keep the access point away from high voltage cables.
- Do not expose the access point in a thunderstorm or strong electric field.
- Cut off the power switch before cleaning the access point.
- Do not open the enclosure when the access point is working.
- Secure the access point tightly.

3.4 Installing the Access Point

⚠ Caution

- You are advised to install the access point where you can get the optimal Wi-Fi coverage.
 - Image is for indicative purpose only and may not represent exact equipment.
-

3.4.1 Installing the Mounting Arm

- (1) Unfasten the four screws on the bottom and keep them aside.

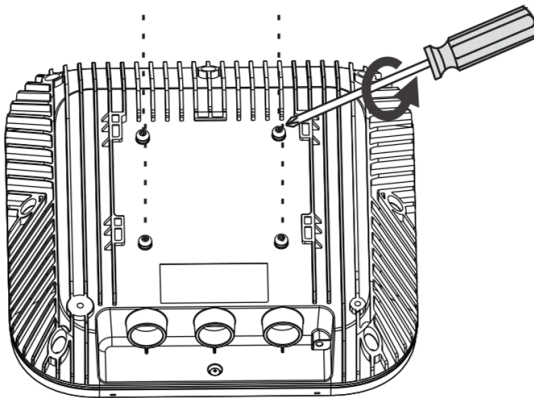

- (2) Wedge the mounting arm into the slot in the orientation indicated by the arrow.

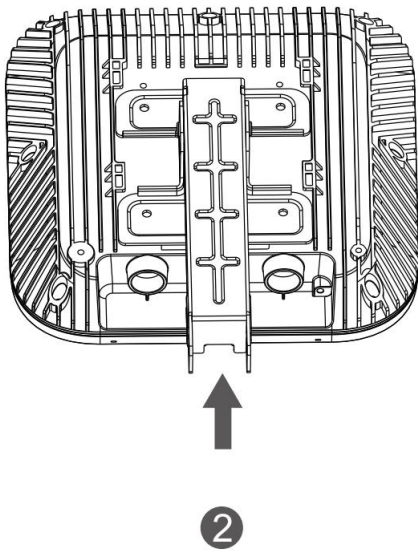

(3) Tighten the four screws using a Philips screwdriver.

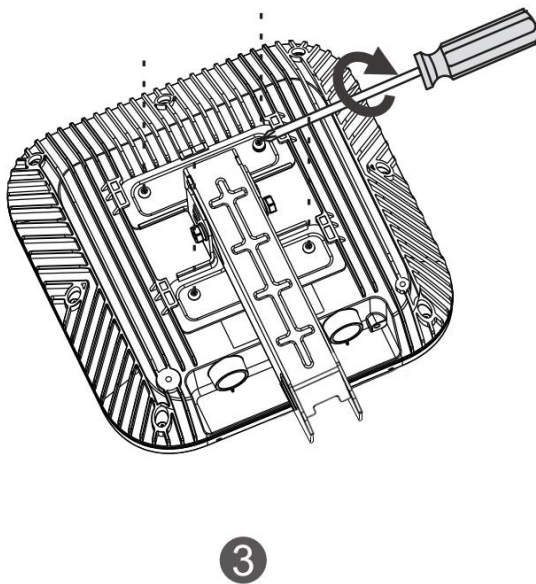

(4) You are advised to drive M8 x 20 screws into the to 6261(CD) screw holes to secure the access point for the convenience of installation.

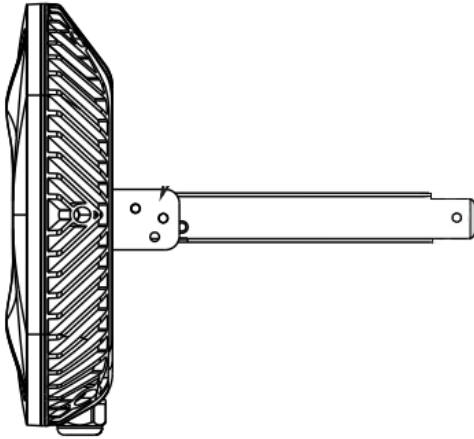

3.4.2 Wall Mounting

Use the mounting plate assembly and M8 x 60 expansion anchors to install the access point.

- (1) Drill four holes with the hole pattern of 65 mm x 105 mm (2.56 in. x 4.13 in.) on the wall.

Figure 3-1 Drilling Holes on Wall

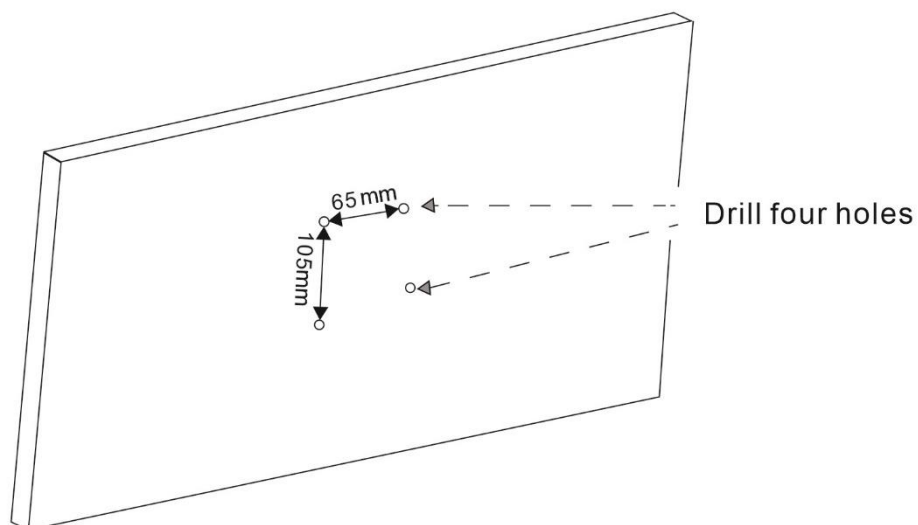

- (2) Attach the mounting plate to the wall with its semicircle opening facing downward. Mark the locations of screw holes. Secure the mounting plate on the wall using M8 x 60 expansion anchors.

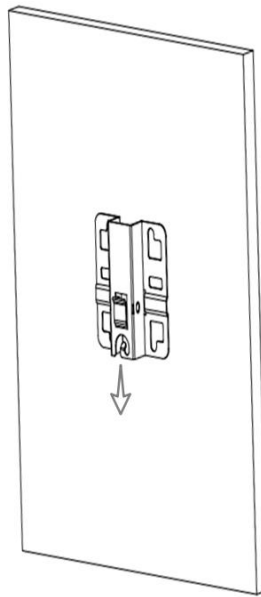
Figure 3-2 Securing Mounting Plate on Wall

- (3) Install the access point and the mounting arm to the mounting plate using M8 x 20 screws.

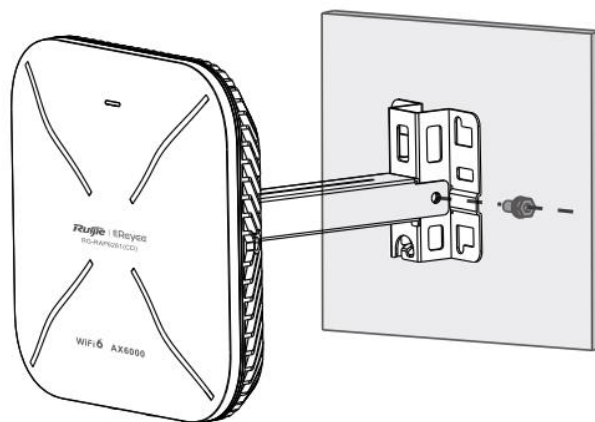
Figure 3-3 Mounting Access Point

3.4.3 Vertical Pole Mounting

- (1) Secure the mounting plate to a vertical pole by threading two hose clamps through the square holes of the mounting plate. Tighten the screws using a Philips screwdriver.

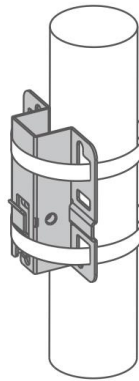
Figure 3-4 Securing Mounting Plate on Vertical Pole

- (2) Install the access point and the mounting arm to the mounting plate using M8 x 20 screws.

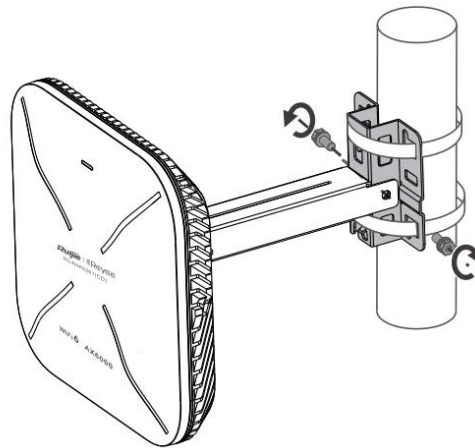
Figure 3-5 Mounting Access Point

3.4.4 Horizontal Pole Mounting

- (1) Secure the mounting plate to a horizontal pole by threading two hose clamps through the square holes of the mounting plate. Tighten the screws using a Philips screwdriver.

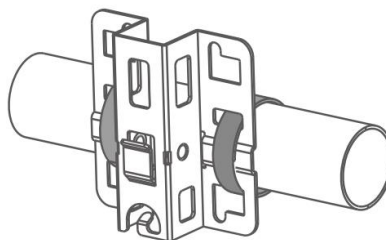
Figure 3-6 Securing Mounting Plate on Horizontal Pole

- (2) Install the access point and the mounting arm to the mounting plate using M8 x 20 screws.

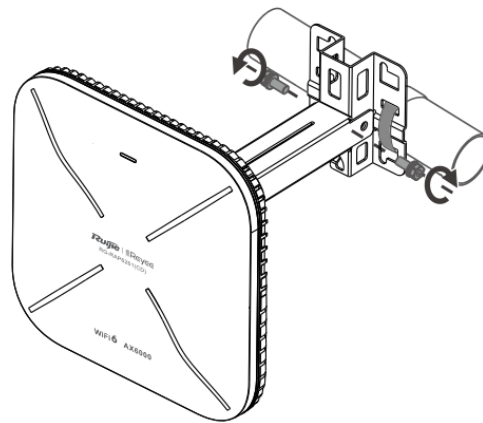
Figure 3-7 Mounting Access Point

3.4.5 Adjusting Orientation

- To adapt to more scenes, you can adjust the access point's orientation. There are two orientations available: horizontal and vertical. After adjusting the orientation, use M8 x 20 screws to secure the access point.

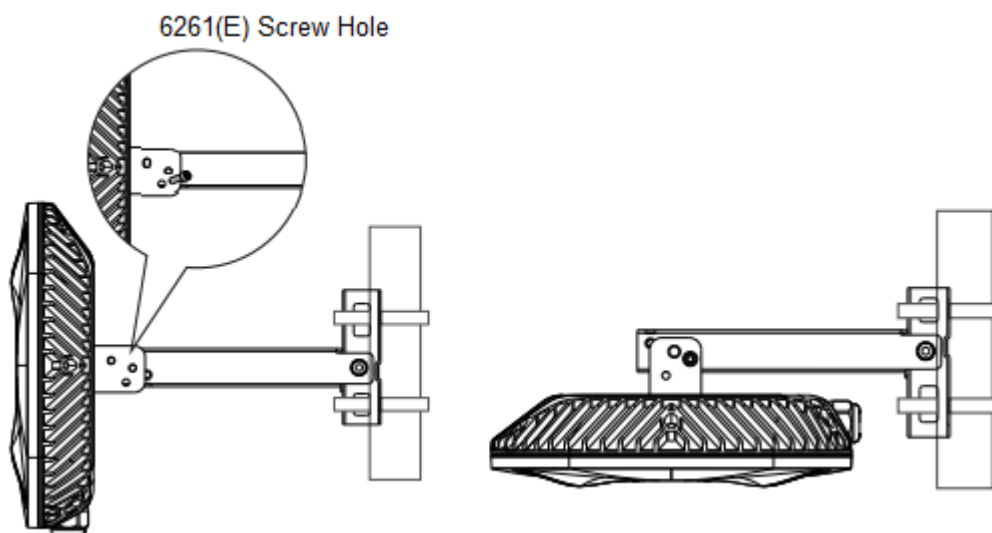

⚠ Caution

- The access point adopts a high-gain omni-directional antenna. Unless otherwise specified, you are advised to mount the access point with its top panel facing downward. Drive the M8 x 20 screws into the 6261(E) screw holes to secure the access point for an optimal Wi-Fi coverage.
- Please make sure the access point is secured in case of falling down.

3.5 Installing the Cable

3.5.1 Installing the Ethernet Cable

- (1) A cable gland assembly includes four components: A (adapter base), B (split gasket), C (grommet), D (compression cap).

- (2) Insert the unterminated end of an Ethernet cable through part D, C, B and A in sequence. Install an RJ-45 connector on the unterminated end of the Ethernet cable. Carefully insert the RJ-45 connector into the Ethernet port of the access point. Thread A (adapter base) into the Ethernet port. Slide B (split gasket) and C (grommet) along the cable, pressing firmly to seat B (gasket) completely into C (grommet).
- (3) Tighten D (compression cap) until C (grommet) and B (gasket) compress on to the cable and provide cable strain relief. Use a waterproof tape to tighten the cable gland.

Figure 3-8 Exploded View of Cable Gland Assembly

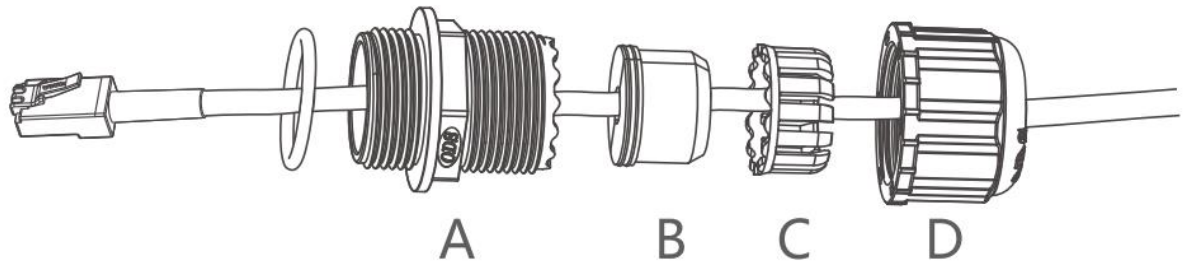

Warning

- The waterproof tape is not included in the package contents.
- Avoid a small bend radius at the connector.
- You are not advised to use an Ethernet cable with an RJ45 boot. The Ethernet cable's diameter should range from 5 mm to 6 mm (0.20 in. to 0.24 in.). The cable gland cannot hold a cable with a diameter beyond this range.
- If you want to use an SFP transceiver (optional accessory), the cable gland can only hold the LC to LC fiber-optic cable with a diameter ranging from 2.8 mm to 3.2 mm (0.11 in. to 0.13 in.).
- When removing the cable gland, proceed in the reverse order of the installation. Start by loosening D (compression cap). Otherwise, the Ethernet cable may be damaged.

3.5.2 Installing the Grounding Cable

- The grounding cable is made on site. Insert the stripped end of the grounding cable into the open end of the grounding lug. Use the crimping tool to secure the grounding cable in the grounding lug. Connect the other end of the grounding cable to an appropriate grounding point in your site to ensure adequate earth ground.
- The grounding screw hole is near the SFP port.
- Trim the power cord on site, avoiding wasting the cord.

3.6 Bundling Cables

3.6.1 Precautions

- The power cords and other cables should be bound in a visually pleasing way.
- When you bundle twisted pairs or fiber-optic cables, make sure that the cables at the connectors have natural bends or bends of large radius.
- Do not over tighten cable bundle as it may reduce the cable life and performance.

3.6.2 Steps

- (1) Bind the drooping part of the cables and place the bundle as near the ports as possible.
- (2) Fasten the cables inside the cable management trough.
- (3) Route the cables under the access point and run in straight line.

3.7 Checking After Installation

- (1) Checking Access Point
 - Verify that the external power supply matches with the requirement of the access point.
 - Verify that the access point is securely fastened.
- (2) Checking Cable Connection
 - Verify that the UTP/STP cable matches with the port type.
 - Verify that cables are properly bundled.
- (3) Checking Power Supply
 - Verify that the power cord is properly connected and compliant with safety requirements.
 - Verify that the access point is operational after power-on.

4 Verifying Operating Status

4.1 Setting up Configuration Environment

The access point can be powered by PoE or local power adapter.

- Verify that the power cord is properly connected and compliant with safety requirements.
- Connect the access point with the debugging device through the Ethernet cable or fiber-optic cable.

4.2 Powering on the Access Point

4.2.1 Checklist Before Power-on

- Verify that the access point has adequate earth ground.
- Verify that the power cord is properly connected.
- Verify that the input voltage meets with the requirement of the access point.

4.2.2 Checklist After Power-on

- Verify that there is system log printed on the terminal interface.
- Verify the LED status.

5 Monitoring and Maintenance

5.1 Monitoring

You can observe the LED color to monitor the access point status.

5.2 Hardware Maintenance

If the hardware is faulty, please contact technical support.

6 Common Troubleshooting

6.1 General Troubleshooting Procedure

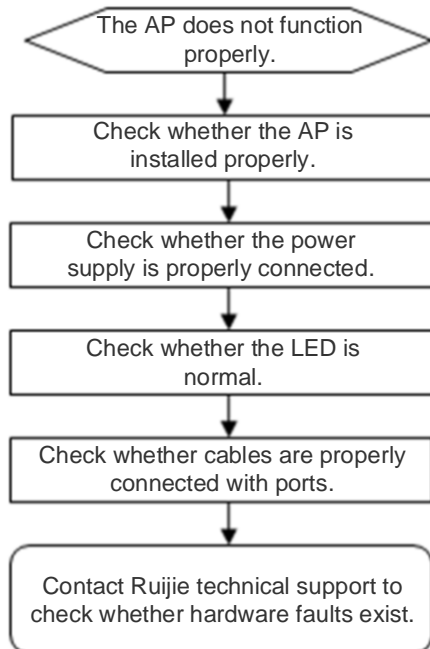

6.2 Common Faults

- Why is the indicator off after the access point is powered on?
 - In a PoE power supply scenario, the power source equipment (PSE) should be at least 802.3at-capable.
 - In a DC power supply scenario, use a power adapter meeting with the following requirement: 48 V DC/1 A.
- Why does Ethernet port not work after the Ethernet cable is plugged in?

Check whether the peer device is working properly. Then verify that the Ethernet cable is capable of providing the required data rate and is properly connected.
- Why can't clients find the access point?
 - Verify that the access point is properly powered.
 - Verify that the Ethernet port is correctly connected.
 - Verify that the access point is correctly configured.
 - Move the client endpoint to adjust the distance between the client and the access point.

7 Appendix

7.1 Connectors and Media

7.1.1 2500BASE-T/1000BASE-T/100BASE-TX/10BASE-T Port

2500BASE-T/1000BASE-T/100BASE-TX/10BASE-T is a 10/100/1000/2500 Mbps self-adaptive port that supports auto MDI/MDIX Crossover.

Compliant with IEEE 802.3bz, 2500BASE-T requires Category 6 or Category 5e 100-ohm UTP or STP (STP is recommended) with a maximum distance of 100 meters (328.08 feet). Category 6 STP is recommended for PoE power supply. Take shielding measures for both ports and cables.

Compliant with IEEE 802.3ab, 1000BASE-T requires Category 6 or Category 5e 100-ohm UTP or STP (STP is recommended) with a maximum distance of 100 meters (328.08 feet). Category 6 STP is recommended for PoE power supply. Take shielding measures for both ports and cables.

2500BASE-T/1000BASE-T port uses four twisted pairs for data transmission. Twisted pairs for the 2500BASE-T/1000BASE-T port are connected as shown in the following figure.

Figure 7-1 Four Twisted Pairs Connection

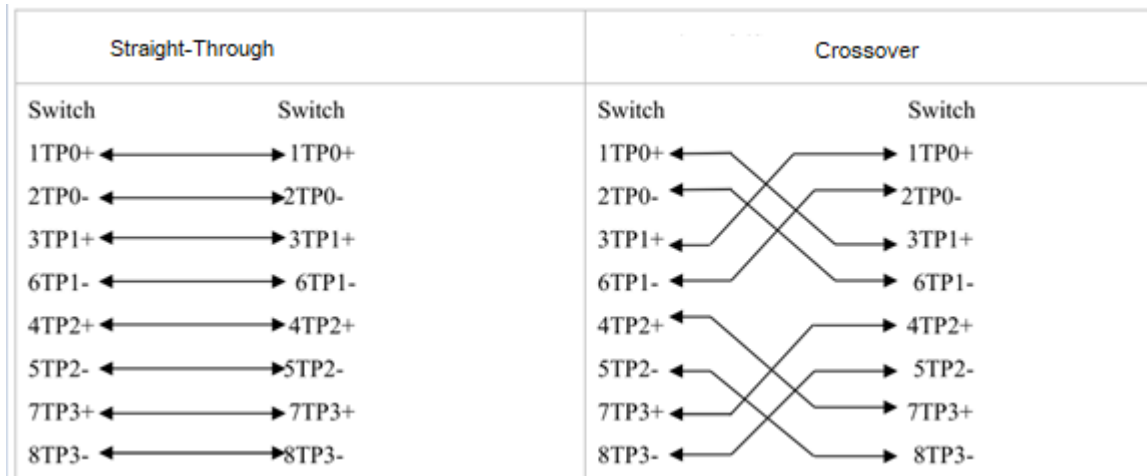

100BASE-TX/10BASE-T port can also be connected by cables of the preceding specifications. Besides, the 10BASE-T port can be connected by 100-ohm Category 3, Category 4, and Category 5 cables with a maximum distance of 100 meters (328.08 feet). 100BASE-TX port can be connected by 100-ohm Category 5 cables with a maximum distance of 100 meters (328.08 feet). The following figure lists definitions of pin signals for the 100BASE-TX/10BASE-T port.

Figure 7-2 100BASE-TX/10BASE-T Pin Assignments

Pin	Socket	Plug
1	Input Receive Data+	Output Transmit Data+
2	Input Receive Data-	Output Transmit Data-
3	Output Transmit Data+	Input Receive Data+
6	Output Transmit Data-	Input Receive Data-
4,5,7,8	Not used	Not used

The following figure shows feasible connections of the straight-through and crossover twisted pairs for a 100BASE-TX/10BASE-T port.

Figure 7-3 100BASE-TX/10BASE-T Connection

Straight-Through		Crossover	
(Switch)	(Adanter)	(Switch)	(Hub/Switch)
1 IRD+	1 OTD+	1 IRD+	1 IRD+
2 IRD-	2 OTD-	2 IRD-	2 IRD-
3 OTD+	3 IRD+	3 OTD+	3 OTD+
6 OTD-	6 IRD-	6 OTD-	6 OTD-

7.1.2 Fiber-Optic Cable Connection

You can choose single-mode or multi-mode fiber-optic cables according to the SFP transceiver types. The following figure shows connection of fiber-optic cable.

Figure 7-4 Fiber-Optic Cable Connection



7.2 Mini-GBIC Modules

We provide different GE SFP transceivers (Mini-GBIC modules). You can select a model to suit your specific needs.

Table 7-1 Mini-GBIC Modules

Mini-GBIC	WL (nm)	Fiber Type	Core Size (µm)	MBW (MHz /km)	Cable Distance	Max Tx Intensity (dBm)	Max Rx Sensitivity (dBm)	STD
FE-SFP-LX-MM1310	1310	MMF	62.5/125	N/A	2 km	-14	-14	IEEE 802.3
FE-SFP-LH15-SM1310	1310	SMF	9/125	N/A	15 km	-8	-8	
MINI-GBIC-SX	850	MMF	62.5 62.5 50.0 50.0	160 200 400 500	220 m 275 m 500 m 550 m	-4	-17	
MINI-GBIC-LX	1310	MMF SMF	62.5 50.0 50.0 9/10	500 400 500 N/A	550 m 550 m 550 m 10 km	-3	-20	
MINI-GBIC	1310	SMF	9/	N/A	40 km	3	-3	

GBIC-LH40			125					
MINI-GBIC-ZX50	1550	SMF	N/A	N/A	50 km	0	-22	
MINI-GBIC-ZX80					80 km	4.7	-22	
MINI-GBIC-ZX100					100 km	5	-9	
Mini-GBIC-GT	N/A	CAT 5 UTP	N/A	N/A	100 m	N/A	N/A	

WL: Wave Length

MBW: Modal Bandwidth

STD: Standard

! **Warning**

- For Mini-GBIC modules with a cabling distance of over 40 km (including 40 km), install an attenuator to avoid overload when using short single-mode fiber-optic cables.
-

7.3 Cabling

During installation, route cable bundles upward or downward along the sides of the rack depending on the actual situation in the equipment room. All cable connectors used for transit should be placed at the bottom of the cabinet rather than be exposed outside of the cabinet. Power cords are routed beside the cabinet, and top cabling or bottom cabling is adopted according to the actual situation in the equipment room, such as the positions of the DC power distribution box, AC socket, or lightning protection box.

(1) Requirements for Cable Bend Radius

- The bend radius of a fixed power cord, network cable, or flat cable should be over five times greater than their respective diameters. The bend radius of these cables that are often bent or plugged should be over seven times greater than their respective diameters.
- The bend radius of a fixed common coaxial cable should be over seven times greater than its diameter. The bend radius of the common coaxial cable that is often bent or plugged should be over 10 times greater than its diameter.
- The bend radius of a fixed high-speed cable (such as SFP+ cable) should be over five times greater than its diameter. The bend radius of the fixed high-speed cable that is often bent or plugged should be over 10 times greater than its diameter.

(2) Precautions for Bundling up Cables

- Before cables are bundled, mark labels and stick the labels to cables wherever appropriate.
- Cables should be neatly and properly bundled in the rack without twisting or bending.

Figure 7-5 Binding Cables

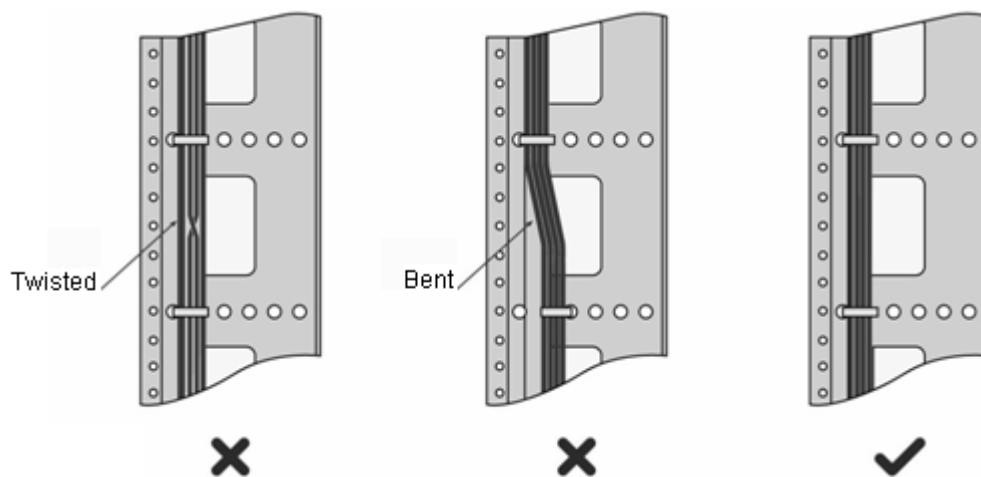

- Cables of different types (such as power cords, signal cables, and ground cables) should be separated in cabling and bundling. Mixed bundling is disallowed. When they are close to each other, you are advised to adopt crossover cabling. In the case of parallel cabling, maintain a minimum distance of 30 mm (1.18 in.) between power cords and signal cables.
- The cable management brackets and cabling troughs inside and outside the cabinet should be smooth without sharp corners.
- The metal hole traversed by cables should have a smooth and fully rounding surface or an insulated lining.
- Use cable ties to bundle up cables properly. Please do not connect two or more cable ties to bundle up cables.

- After bundling up cables with cable ties, cut off the remaining part. The cut should be smooth and trim, without sharp corners.

Figure 7-6 Binding Cables

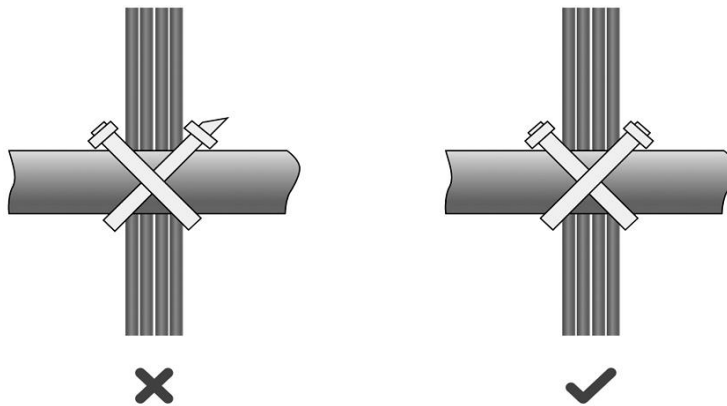

- When cables need to be bent, please bundle them up but do not tie them where the cables will be bent. When cables need to be bent, please bundle them up but do not tie them where the cables will be bent.

Figure 7-7 Binding Cables

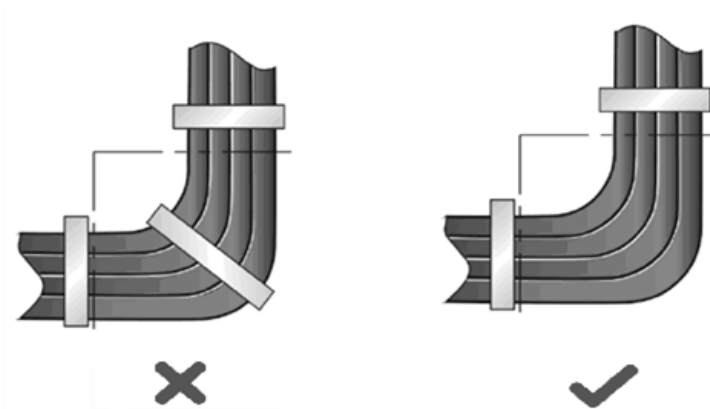

- Cables not to be assembled or remaining parts of cables should be folded and placed in a proper position of the rack or cable trough. The proper position refers to a position that does not affect device running or damage the device or cable.
- 220 V and -48 V power cords must not be bundled on the guide rails of moving parts.
- The power cords connecting moving parts such as grounding cables should be reserved with some access after being assembled to avoid suffering tension or stress. After the moving part is installed, the remaining cable part should not touch heat sources, sharp corners, or sharp edges. If heat sources cannot be avoided, high-temperature cables should be used. If heat sources cannot be avoided, high-temperature cables should be used.
- When screw threads are used to fasten cable terminals, the anchor or screw must be tightly fastened.

Figure 7-8 Cable Fastening

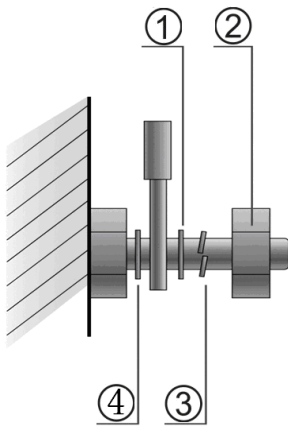

1. Flat Washer	3. Spring Washer
2. Nut	4. Flat Washer

- Hard power cords should be fastened in the terminal connection area to prevent stress on terminal connection and cable.
- Do not use self-tapping screws to fasten terminals.
- power cords of the same type and in the same cabling direction should be bundled up into cable bunches, with cables in cable bunches clean and straight.
- Bundle up cables by using cable ties.

Cable Bunch Diameter	Distance between Every Binding Point
10 mm (0.39 in.)	80 mm to 150 mm (3.15 in. to 5.91 in.)
10 mm to 30 mm (0.39 in. to 1.18 in.)	150 mm to 200 mm (5.91 in. to 7.87 in.)
30 mm (1.18 in.)	200 mm to 300 mm (7.87 in. to 11.81 in.)

- No knot is allowed in cabling or bundling.

For wiring terminal blocks (such as circuit breakers) with cord end terminals, the metal part of the cord end terminal should not be exposed outside the terminal block when assembled.