

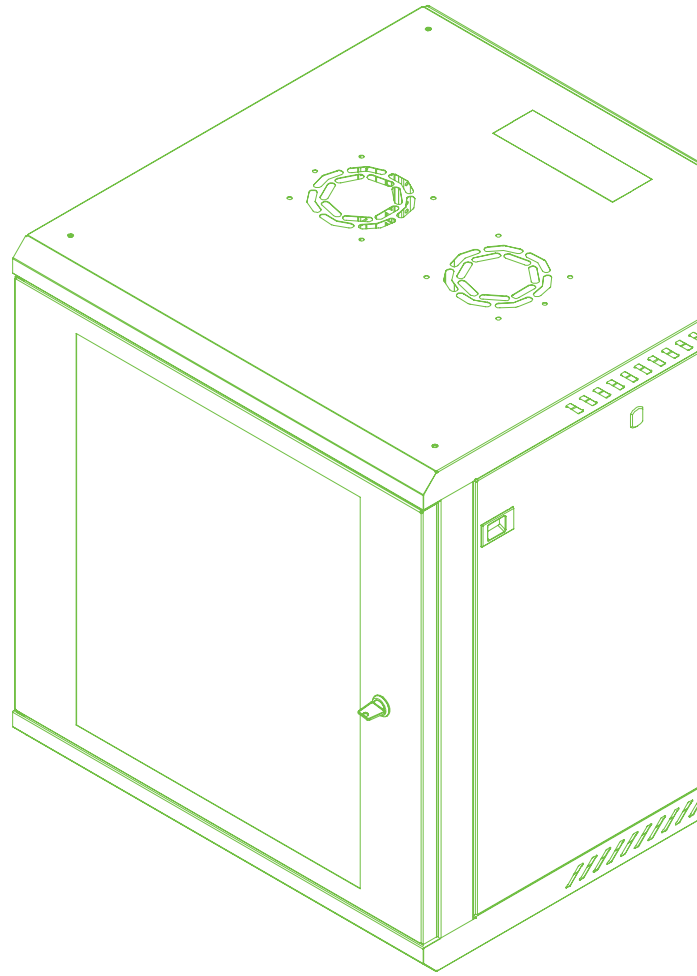

WIREWİN

EN



# WCAB PS3 600X600

19" WALL CABINETS  
600X600MM, GREY RAL7035 / BLACK RAL9005



## PRODUCT DESCRIPTION

The WIREWIN® PS3 Series network enclosures have been developed for easy assembly and optimized shipping logistics.

With a load capacity of up to 100 kg (tested), they are ideal for heavy telecommunications equipment, UPS systems and batteries - not just for standard network technology.

The PS3 Series includes models in 600x450 mm and 600x600 mm, available in heights from 4U to 18U. As standard, the cabinets have a safety glass front door and removable side panels with 2 slam latches. An optional locking cylinder can be installed for increased security.

With their professional, aesthetic design and transparent glass doors, the cabinets are available in RAL 9005 black and RAL 7035 light gray with soft-touch paint.

The standardized and stocked product portfolio enables space-saving cardboard packaging for models up to 18U. The PS3 Series models are equipped with two 19" rails ex works.

## FEATURES

- WIREWIN® 19" single section Wallmount Cabinet
- Safety Glasdoor, lockable
- Side panels are also fitted with a Snap-In fastener
- 2 pairs 19" mounting Rails, Front Rails are adjustable, Rear Rails are fixed
- detachable Side Panels with special hidden spring loaded pin system
- 600 mm width
- 600 mm depth, 450 mm available
- 4U / 6U / 9U / 12U / 15U / 18U heights
- tested with 100 kg load
- Packaging: single, carton packaging, assembled

## DIMENSIONS

- Width: 600mm
- Depth: 600mm
- Height: 4U (280mm) / 6U (369mm) / 9U (503mm) / 12U (636mm) / 15U (770mm) 18U (903mm)

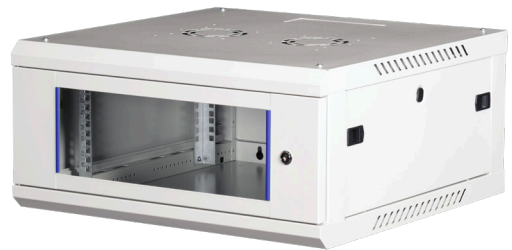



### 19" PS3 Series Wall Mounting Cabinet Material Thickness (mm)

U Height	Top Cover	Bottom Panel	Frame (Horizontal Part)	Frame (Vertical Part)	Front Door (Vertical Part)	Front Door (Horizontal Part)	Rear Panel	Side Panels	19" Rails
4U	0.6	0.6	1.1	0.9	0.6	0.5	0.5	0.5	1.4
6U	0.6	0.6	1.1	0.9	0.6	0.5	0.5	0.5	1.4
9U	0.6	0.6	1.1	0.9	0.6	0.5	0.5	0.5	1.4
12U	0.6	0.6	1.1	1.1	0.6	0.5	0.5	0.5	1.4
15U	0.6	0.6	1.1	1.1	0.6	0.5	0.5	0.5	1.4
18U	0.6	0.6	1.1	1.1	0.6	0.5	0.5	0.5	1.4

### 19" PS3 Series Wall Mounting Cabinet Dimensions / Weight / Colour RAL7035 Grey

Units	Part Number	Product Size WxDxH mm	Flat Pack Dimensions	h mm	Net Weight (kg)	Gross Weight (kg)	EAN
4U	WCAB PS3 600X600X4U	600X600x280	-	178	12.25	13.65	9120117659265
6U	WCAB PS3 600X600X6U	600X600x369	-	267	13.90	15.3	9120117659302
9U	WCAB PS3 600X600X9U	600X600x503	-	400	16.35	17.75	9120117659340
12U	WCAB PS3 600X600X12U	600X600x636	-	533	19.2	20.6	9120117659388
15U	WCAB PS3 600X600X15U	600X600x770	-	667	22	23.4	9120117659425
18U	WCAB PS3 600X600X18U	600X600x903	-	800	24.7	24.70	9120117659463

### 19" PS3 Series Wall Mounting Cabinet Dimensions / Weight / Colour RAL 9005 Black

Units	Part Number	Product Size WxDxH mm	Flat Pack Dimensions	h mm	Net Weight (kg)	Gross Weight (kg)	EAN
4U	WCAB PS3 600X600X4U B	600X600x280	-	178	12.25	13.65	9120117659289
6U	WCAB PS3 600X600X6U B	600X600x369	-	267	13.90	15.3	9120117659326
9U	WCAB PS3 600X600X9U B	600X600x503	-	400	16.35	17.75	9120117659364
12U	WCAB PS3 600X600X12U B	600X600x636	-	533	19.2	20.6	9120117659401
15U	WCAB PS3 600X600X15U B	600X600x770	-	667	22	23.4	9120117659449
18U	WCAB PS3 600X600X18U B	600X600x903	-	800	24.7	24.70	9120117659487





---

### Compliance with Standards

---

- With the EN 12150-1 standard antistatic, transparent safety glass 4,0 mm front glass door.
- Round quarter turn lock which is compatible with DIN 1743, DIN 53571, RoHS.
- EN 60297- Mechanical constructions for electrical devices. mechanical constructions (19 inch series) with standard universal 482,6 mm profiles
- EN 60917- Modular layout for development of mechanical constructions in electronic equipment applications.
- EN 61587-1 For electronic devices inner usage mechanic construction cabinets, bottom shelves, cases, IEC 60917 and IEC 60297 series tests, Chapter 1, environmental conditions, test setup and security rules.
- EIA/ ECA-310 (D/E) 19" 482,6 mm and U 44,45 mm Height Sizing
- Climatic and environment: EN 61587-1/4.2, IEC 60068-2-1, IEC 60068-2-2, IEC 60068-2-30
- Static Mechanical Load Lifting: EN 61587-1/5.2.1
- Static Mechanical Load Stiffness: EN 61587-1/5.2.2
- Dynamic mechanical load vibration and shock, impact: EN 61587-1/5.3.1, EN 61587-1/5.3.3, IEC 60068-2-6, IEC 60068-2-27
- Grounding: EN 61587-1/6.2
- Fireproofing: EN 61587-1/6.3
- IP protection class (IP code): IP20, EN 61587-1/6.4
- The powder paint used is non-flammable and has a flame-retardant resistant according to TS EN 13501-1 + A1 standard
- TS EN ISO 9227 corrosion tests, salt spraying tests, TS EN ISO 2409 paints and varnishes, cross cutting test, TS 2311 EN ISO2178 above magnetic metals non-magnetic covering, measuring covering thickness, magnetic method
- 2011/65/EU- regulation of hazardous material restriction/ RoHS suitability
- TS EN 60950-1 information technology devices, Security- Chapter 1
- General rules- CE conformity
- Sheet steel: DIN 934, DIN 985, DIN 933 - EN ISO 2081 metallic and other inorganic coverings covered above iron or steel with the additional process electrolytic zinc covering standards

---

### Production Facility Standards

---

- ISO 9001- Quality Control System
  - ISO 14001- Environmental Management System
  - ISO 45001- Occupational Health and Safety Management System
-



Technical Drawings

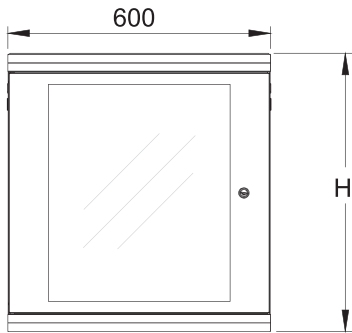

Front view

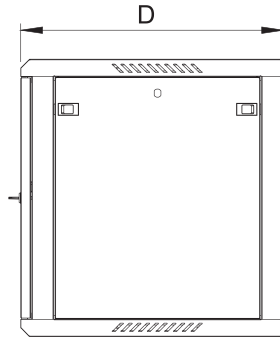

Side view

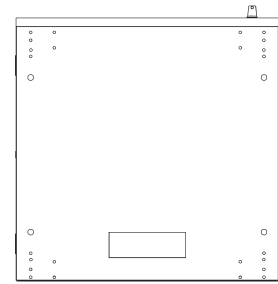

Bottom view

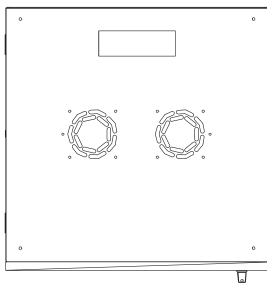

Top view

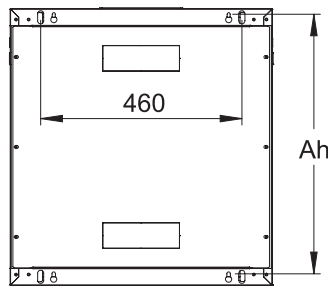

Rear view

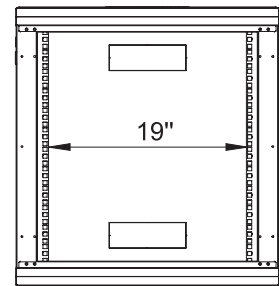

Front inside view

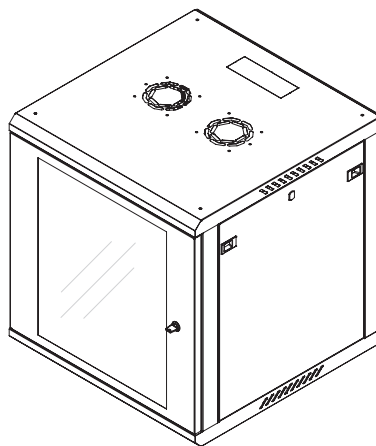

Isometric view



Technical Drawings

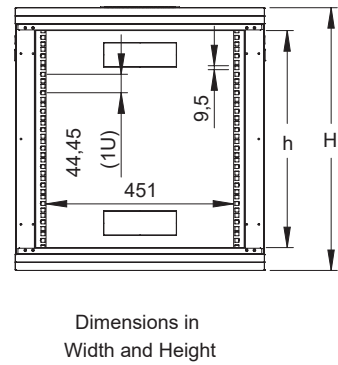
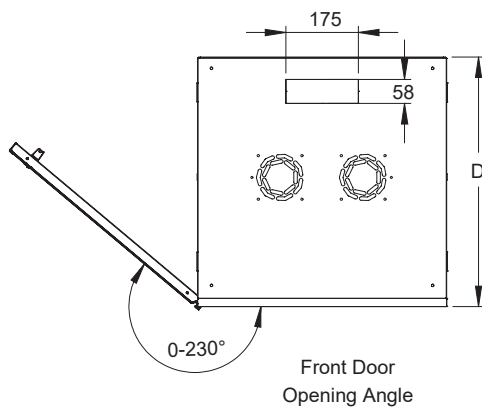
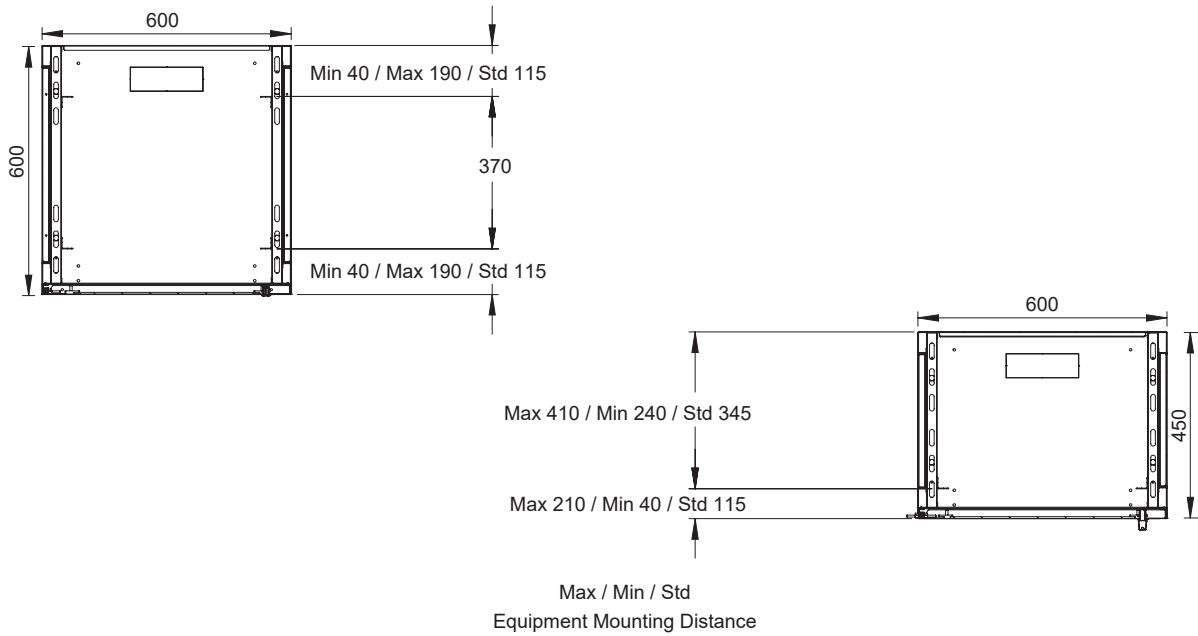

U Height	Size D	h	H	Ah
4U	600	178	290	251
6U	600	267	379	340
9U	600	400	512	473
12U	600	533	645	606
15U	600	667	779	740
18U	600	800	912	873



Explode View

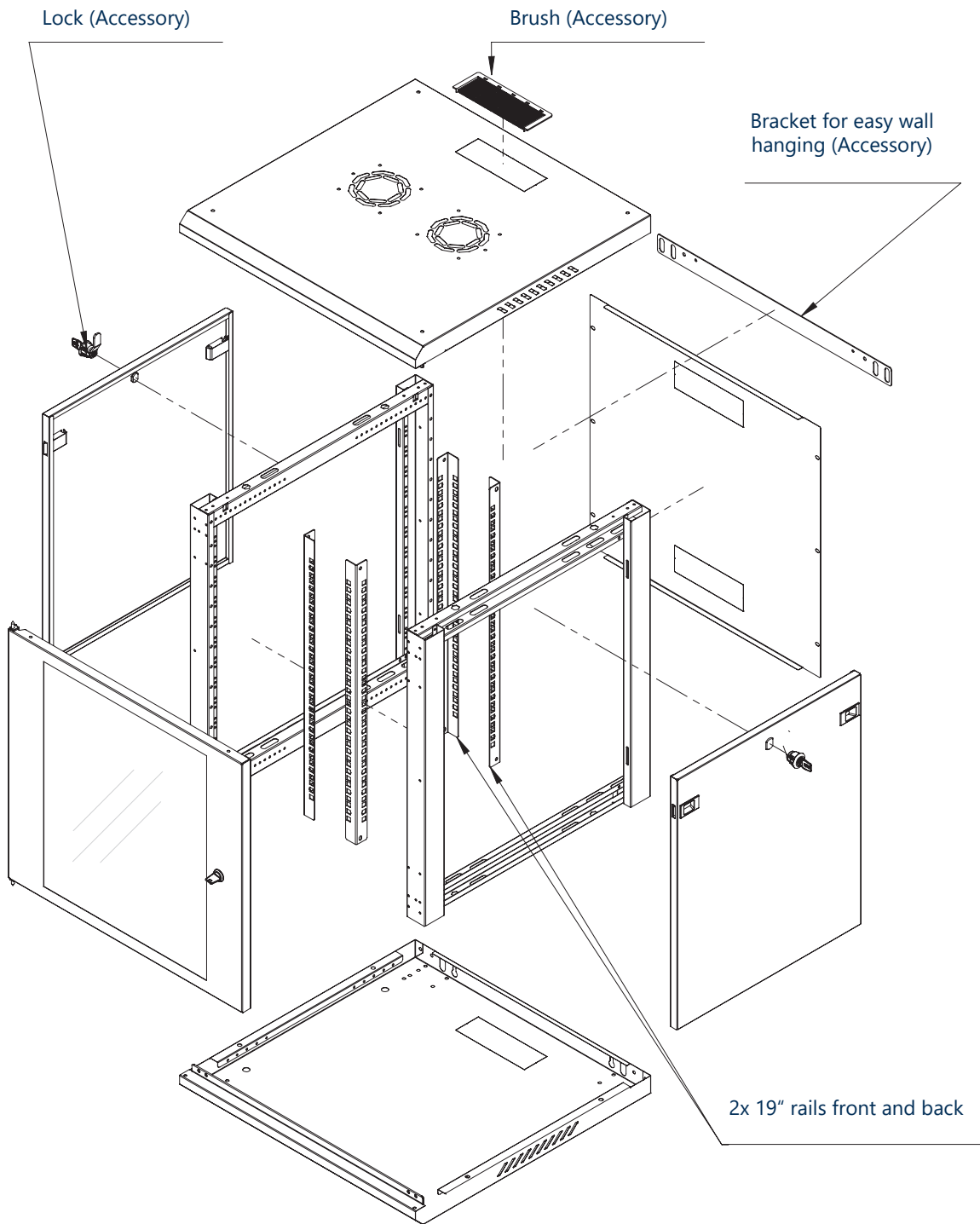



T: +43 31 72 / 4 22 99-0  
F: +43 31 72 / 4 22 99-11



Energiestraße 10  
8160 Weiz  
Austria



[office@triotronik.com](mailto:office@triotronik.com)  
[www.triotronik.com](http://www.triotronik.com)