

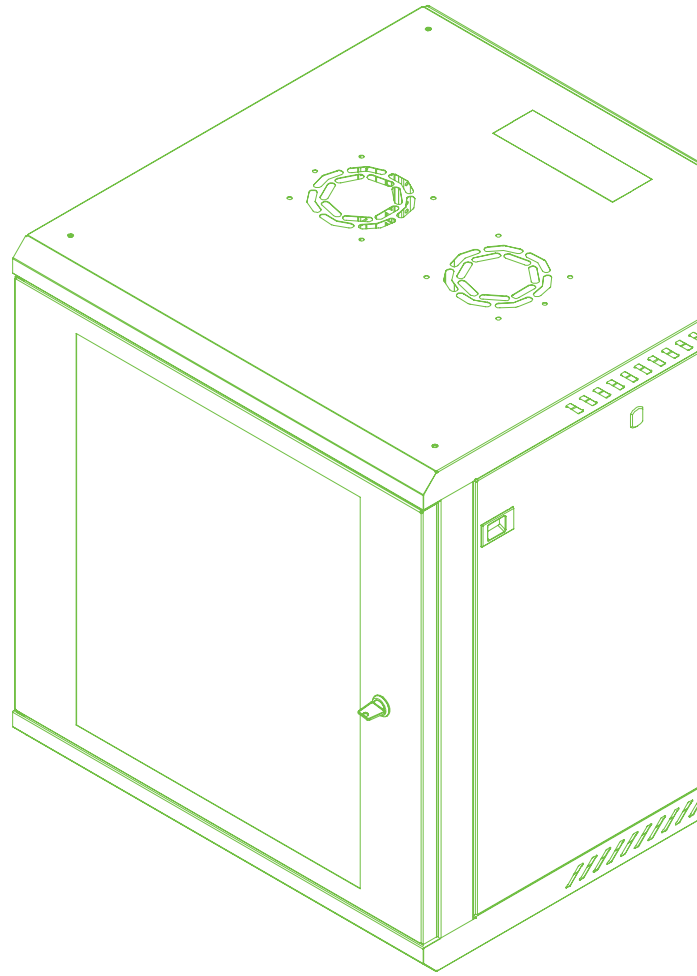

WIREWİN

EN



# WCAB PS3 600X450

19" WALL CABINETS  
600X450MM, GREY RAL7035 / BLACK RAL9005



## PRODUCT DESCRIPTION

The WIREWIN® PS3 Series network enclosures have been developed for easy assembly and optimized shipping logistics.

With a load capacity of up to 100 kg (tested), they are ideal for heavy telecommunications equipment, UPS systems and batteries - not just for standard network technology.

The PS3 Series includes models in 600x450 mm and 600x600 mm, available in heights from 4U to 18U. As standard, the cabinets have a safety glass front door and removable side panels with 2 slam latches. An optional locking cylinder can be installed for increased security.

With their professional, aesthetic design and transparent glass doors, the cabinets are available in RAL 9005 black and RAL 7035 light gray with soft-touch paint.

The standardized and stocked product portfolio enables space-saving cardboard packaging for models up to 18U. The PS3 Series models are equipped with two 19" rails ex works.

## FEATURES

- WIREWIN® 19" single section Wallmount Cabinet
- Safety Glasdoor, lockable
- Side panels are also fitted with a Snap-In fastener
- 2 pairs 19" mounting Rails, Front Rails are adjustable, Rear Rails are fixed
- 600 mm width
- 450 mm depth, 600 mm available
- 4U / 6U / 9U / 12U / 15U / 18U heights
- tested with 100 kg load
- Packaging: single, carton packaging, assembled

## DIMENSIONS

- Width: 600mm
- Depth: 450mm
- Height: 4U (280mm) / 6U (369mm) / 9U (503mm) / 12U (636mm) / 15U (770mm) 18U (903mm)





### 19" PS3 Series Wall Mounting Cabinet Material Thickness (mm)

U Height	Top Cover	Bottom Panel	Frame (Horizontal Part)	Frame (Vertical Part)	Front Door (Vertical Part)	Front Door (Horizontal Part)	Rear Panel	Side Panels	19" Rails
4U	0.6	0.6	1.1	0.9	0.6	0.5	0.5	0.5	1.4
6U	0.6	0.6	1.1	0.9	0.6	0.5	0.5	0.5	1.4
9U	0.6	0.6	1.1	0.9	0.6	0.5	0.5	0.5	1.4
12U	0.6	0.6	1.1	0.9	0.6	0.5	0.5	0.5	1.4
15U	0.6	0.6	1.1	1.1	0.6	0.5	0.5	0.5	1.4
18U	0.6	0.6	1.1	1.1	0.6	0.5	0.5	0.5	1.4

### 19" PS3 Series Wall Mounting Cabinet Dimensions / Weight / Colour RAL7035 Grey

Units	Part Number	Product Size WxDxH mm	Flat Pack Dimensions	h mm	Net Weight (kg)	Gross Weight (kg)	EAN
4U	WCAB PS3 600X450X4U	600x450x280	-	178	9.8	10.7	9120117659029
6U	WCAB PS3 600X450X6U	600x450x369	-	267	11.25	12.15	9120117659067
9U	WCAB PS3 600X450X9U	600x450x503	-	400	13.45	14.45	9120117659104
12U	WCAB PS3 600X450X12U	600x450x636	-	533	15.6	17	9120117659142
15U	WCAB PS3 600X450X15U	600x450x770	-	667	18.2	20.2	9120117659180
18U	WCAB PS3 600X450X18U	600x450x903	-	800	20.55	22.75	9120117659227

### 19" PS3 Series Wall Mounting Cabinet Dimensions / Weight / Colour RAL 9005 Black

Units	Part Number	Product Size WxDxH mm	Flat Pack Dimensions	h mm	Net Weight (kg)	Gross Weight (kg)	EAN
4U	WCAB PS3 600X450X4U B	600x450x280	-	178	9.8	10.7	9120117659043
6U	WCAB PS3 600X450X6U B	600x450x369	-	267	11.25	12.15	9120117659081
9U	WCAB PS3 600X450X9U B	600x450x503	-	400	13.45	14.45	9120117659128
12U	WCAB PS3 600X450X12U B	600x450x636	-	533	15.6	17	9120117659166
15U	WCAB PS3 600X450X15U B	600x450x770	-	667	18.2	20.2	9120117659203
18U	WCAB PS3 600X450X18U B	600x450x903	-	800	20.55	22.75	9120117659241





---

### Compliance with Standards

---

- With the EN 12150-1 standard antistatic, transparent safety glass 4,0 mm front glass door.
- Round quarter turn lock which is compatible with DIN 1743, DIN 53571, RoHS.
- EN 60297- Mechanical constructions for electrical devices. mechanical constructions (19 inch series) with standard universal 482,6 mm profiles
- EN 60917- Modular layout for development of mechanical constructions in electronic equipment applications.
- EN 61587-1 For electronic devices inner usage mechanic construction cabinets, bottom shelves, cases, IEC 60917 and IEC 60297 series tests, Chapter 1, environmental conditions, test setup and security rules.
- EIA/ ECA-310 (D/E) 19" 482,6 mm and U 44,45 mm Height Sizing
- Climatic and environment: EN 61587-1/4.2, IEC 60068-2-1, IEC 60068-2-2, IEC 60068-2-30
- Static Mechanical Load Lifting: EN 61587-1/5.2.1
- Static Mechanical Load Stiffness: EN 61587-1/5.2.2
- Dynamic mechanical load vibration and shock, impact: EN 61587-1/5.3.1, EN 61587-1/5.3.3, IEC 60068-2-6, IEC 60068-2-27
- Grounding: EN 61587-1/6.2
- Fireproofing: EN 61587-1/6.3
- IP protection class (IP code): IP20, EN 61587-1/6.4
- The powder paint used is non-flammable and has a flame-retardant resistant according to TS EN 13501-1 + A1 standard
- TS EN ISO 9227 corrosion tests, salt spraying tests, TS EN ISO 2409 paints and varnishes, cross cutting test, TS 2311 EN ISO2178 above magnetic metals non-magnetic covering, measuring covering thickness, magnetic method
- 2011/65/EU- regulation of hazardous material restriction/ RoHS suitability
- TS EN 60950-1 information technology devices, Security- Chapter 1
- General rules- CE conformity
- Sheet steel: DIN 934, DIN 985, DIN 933 - EN ISO 2081 metallic and other inorganic coverings covered above iron or steel with the additional process electrolytic zinc covering standards

---

### Production Facility Standards

---

- ISO 9001- Quality Control System
  - ISO 14001- Environmental Management System
  - ISO 45001- Occupational Health and Safety Management System
-



Technical Drawings

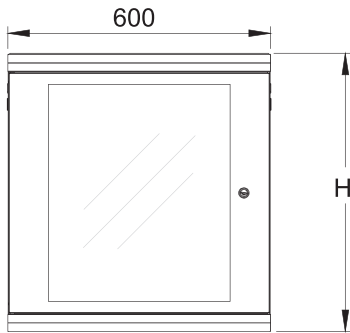

Front view

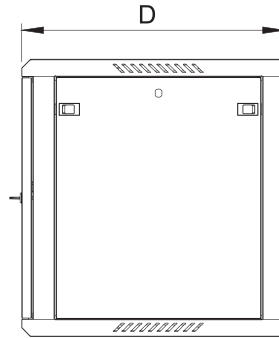

Side view

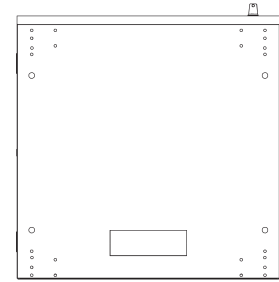

Bottom view

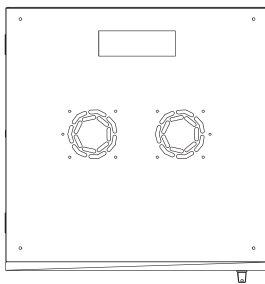

Top view

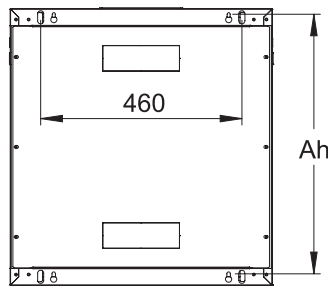

Rear view

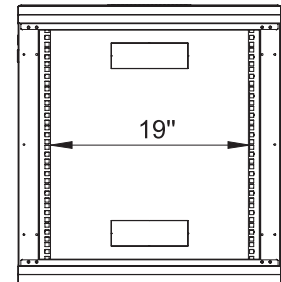

Front inside view

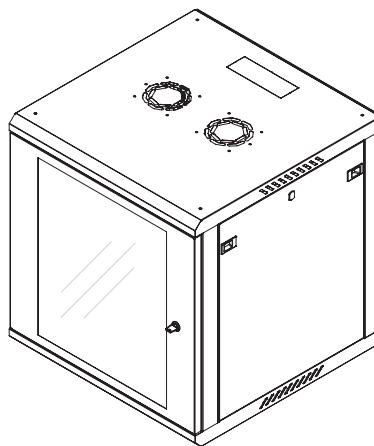

Isometric view



Technical Drawings

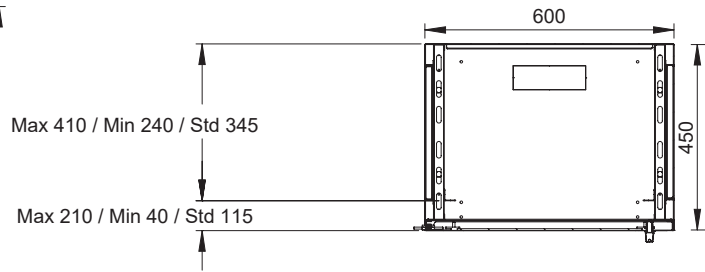
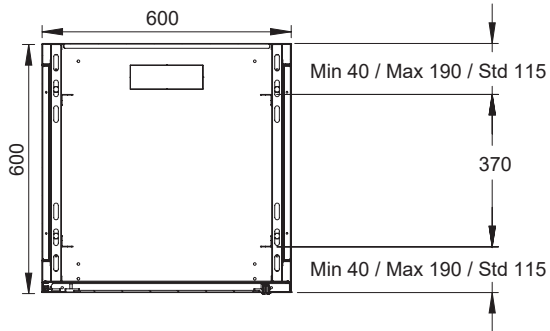

Max / Min / Std  
Equipment Mounting Distance

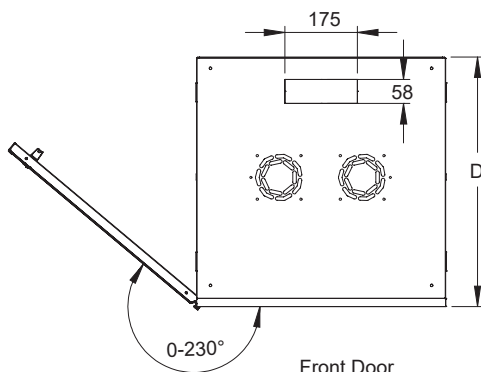

Front Door  
Opening Angle

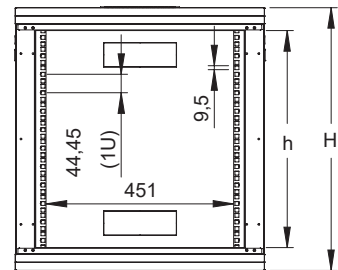

Dimensions in  
Width and Height

U Height	Size D	h	H	Ah
4U	450	178	290	251
6U	450	267	379	340
9U	450	400	512	473
12U	450	533	645	606
15U	450	667	779	740
18U	450	800	912	873



Explode View

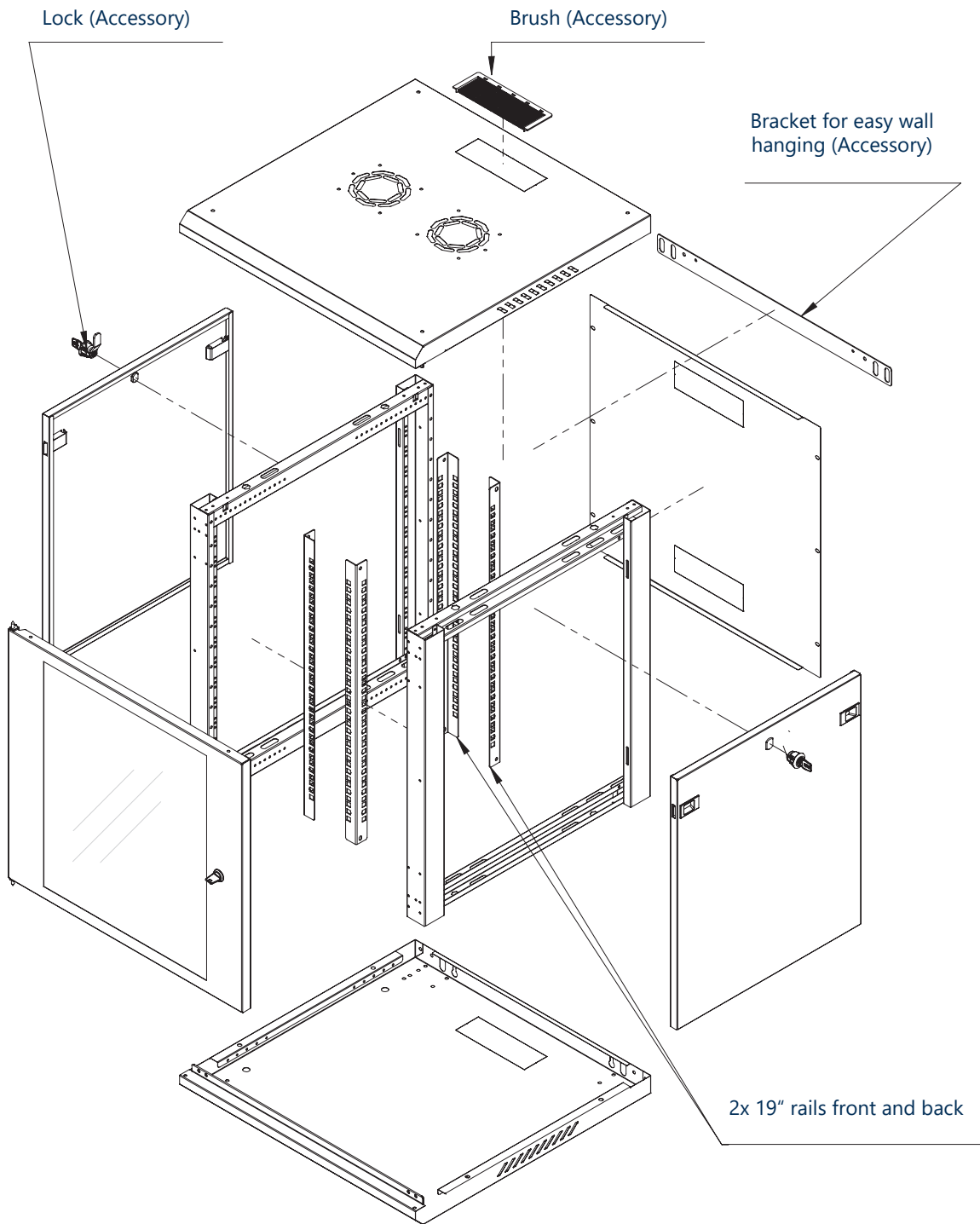



T: +43 31 72 / 4 22 99-0  
F: +43 31 72 / 4 22 99-11



Energiestraße 10  
8160 Weiz  
Austria



[office@triotronik.com](mailto:office@triotronik.com)  
[www.triotronik.com](http://www.triotronik.com)