

LWO-QSFP28-LR4-HPE

100Gbit QSFP28 LR4, 10km, DFB, LC-Duplex, SM, Enterprise Version, HP Aruba

Features

- Hot-pluggable QSFP28 form factor
- Duplex LC receptacle optical interface
- Transmitter: cooled 4x25Gb/s DML laser
- Receiver: 4x25Gb/s PIN receiver
- Compliant with CEI-28G-VSR
- HP Aruba Coding
- Single +3.3V power supply
- Low power dissipation (max: 4.0W)
- Built in digital diagnostic function
- Operating case temperature range 0°C to 70°C

Application

- 100GBASE-LR4
- InfinibandQDR and DDR interconnects
- Client-side 100G Telecom connections

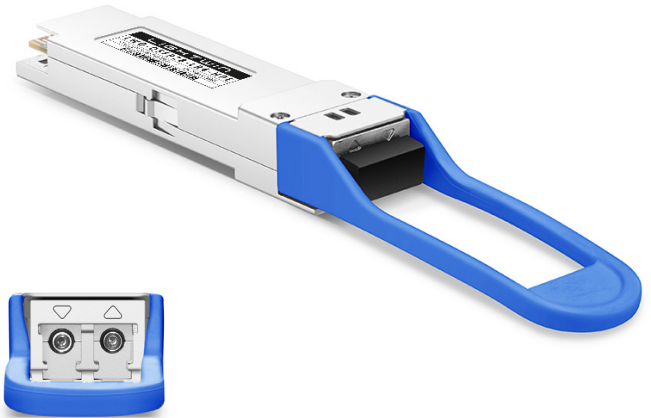

Functional Description

The 100G QSFP28 LR4 optical transceiver integrates the transmit and receive path onto one module. On the transmit side, four lanes of serial data streams are recovered, retimed, and passed on to four laser drivers, which control four lasers with 1295.5, 1300.0, 1304.5, and 1309.1nm center wavelengths. The optical signals are then multiplexed into a single-mode fiber through an industry-standard LC connector. On the receive side, four lanes of optical data streams are optically demultiplexed by an integrated optical demultiplexer. Each data stream is recovered by a photodetector and transimpedance amplifier, retimed, and passed on to an output driver. This module features a hot-pluggable electrical interface, low power consumption, and 2-wire serial interface.

Transceiver Block Diagram

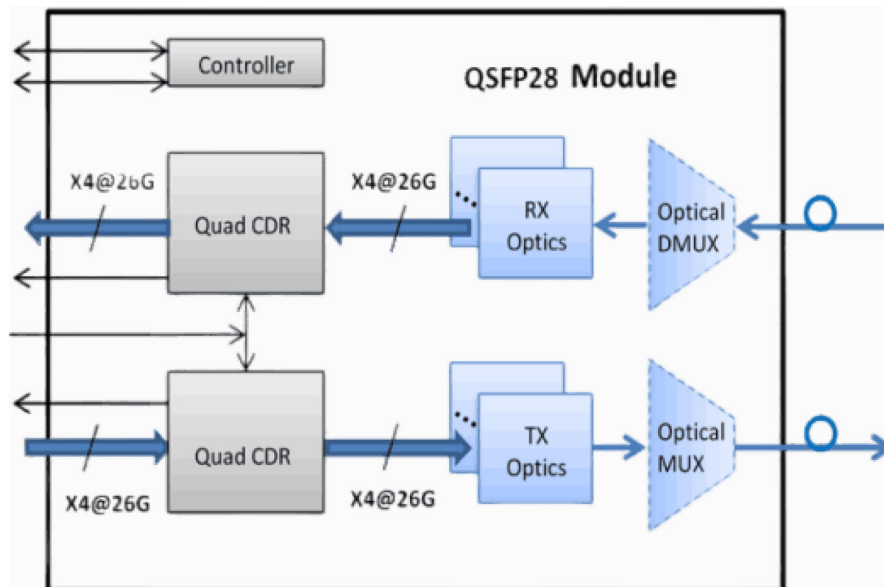

Figure 1. Transceiver Block Diagram

LWO-QSFP28-LR4-HPE

100Gbit QSFP28 LR4, 10km, DFB, LC-Duplex, SM, Enterprise Version, HP Aruba

Recommended Power Supply Filter

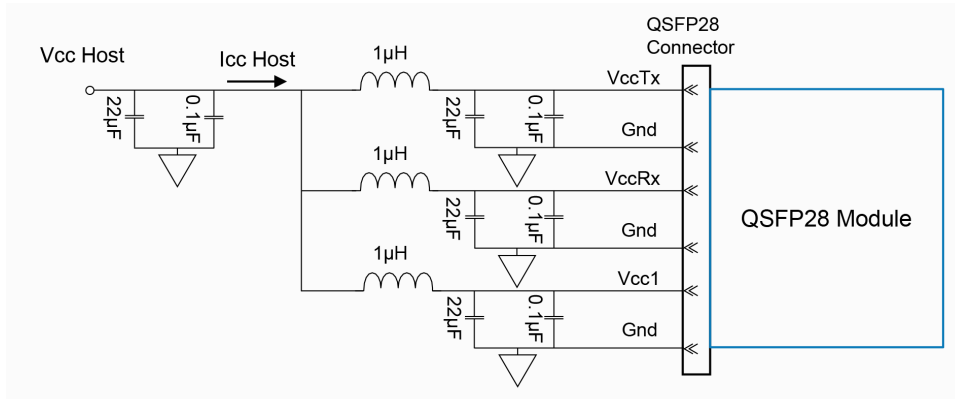

Figure 3. Recommended Power Supply Filter

Pin Assignment and Description

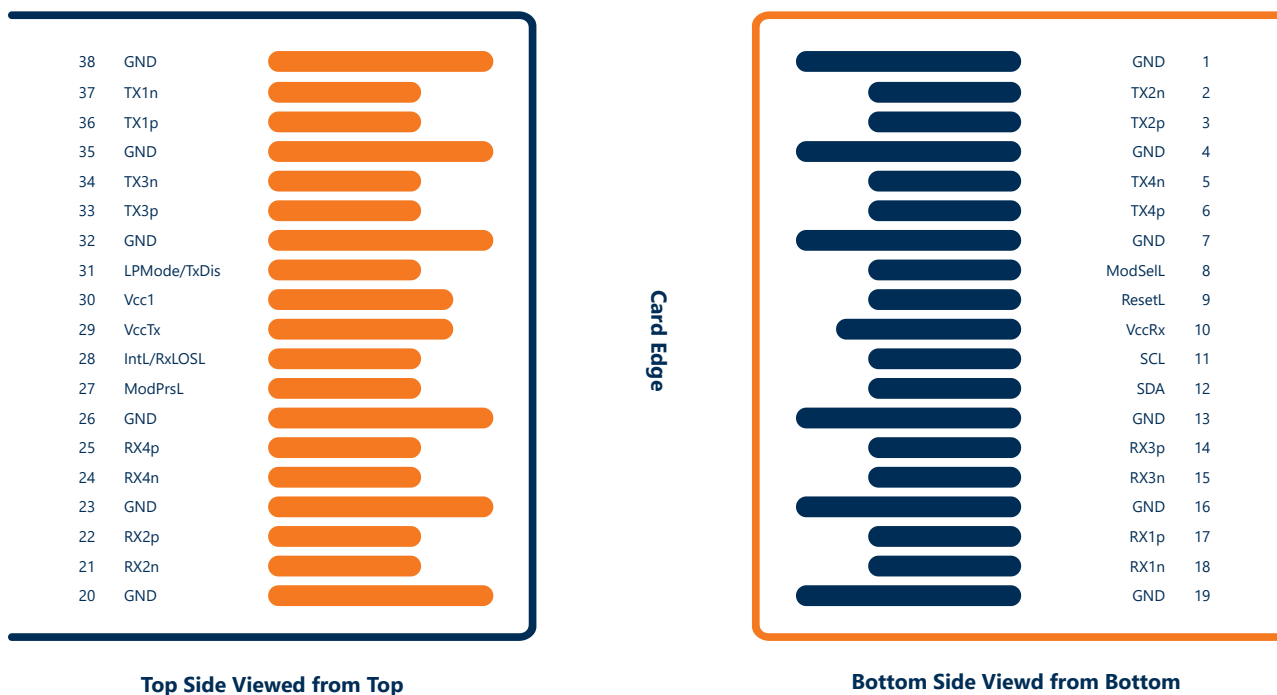

Figure 2. HP Aruba Compliant Connector

LWO-QSFP28-LR4-HPE

100Gbit QSFP28 LR4, 10km, DFB, LC-Duplex, SM, Enterprise Version, HP Aruba

PIN Definition

PIN	Logic	Symbol	Name/Description	Notes
1		GND	Ground	1
2	CML-I	Tx2n	Transmitter Inverted Data Input	
3	CML-I	Tx2p	Transmitter Non-Inverted Data output	
4		GND	Ground	1
5	CML-I	Tx4n	Transmitter Inverted Data Input	
6	CML-I	Tx4p	Transmitter Non-Inverted Data output	
7		GND	Ground	1
8	LVTTL-I	ModSelL	Module Select	
9	LVTTL-I	ResetL	Module Reset	
10		VccRx	+3.3V Power Supply Receiver	2
11	LVC MOS-I/O	SCL	2-Wire Serial Interface Clock	
12	LVC MOS-I/O	SDA	2-Wire Serial Interface Data	
13		GND	Ground	1
14	CML-O	Rx3p	Receiver Non-Inverted Data Output	
15	CML-O	Rx3n	Receiver Inverted Data Output	
16		GND	Ground	1
17	CML-O	Rx1p	Receiver Non-Inverted Data Output	
18	CML-O	Rx1n	Receiver Inverted Data Output	
19		GND	Ground	1
20		GND	Ground	1
21	CML-O	Rx2n	Receiver Inverted Data Output	
22	CML-O	Rx2p	Receiver Non-Inverted Data Output	
23		GND	Ground	1
24	CML-O	Rx4n	Receiver Inverted Data Output	1
25	CML-O	Rx4p	Receiver Non-Inverted Data Output	
26		GND	Ground	1
27	LVTTL-O	ModPrsL	Module Present	
28	LVTTL-O	IntL/RxLOSL	Interrupt. Optionally configurable as RxLOSL via the management interface (SFF-8636)	
29		VccTx	+3.3V Power Supply transmitter	2
30		Vcc1	+3.3 V Power Supply	2
31	LVTTL-I	LP MODE/TxDis	Low Power Mode. Optionally configurable as TxDis via the management interface (SFF-8636)	
32		GND	Ground	1
33	CML-I	Tx3p	Transmitter Non-Inverted Data Input	
34	CML-I	Tx3n	Transmitter Inverted Data Input	
35		GND	Ground	1
36	CML-I	Tx1p	Transmitter Non-Inverted Data Input	
37	CML-I	Tx1n	Transmitter Inverted Data Output	
38		GND	Ground	1

Notes

- GND is the symbol for signal and supply (power) common for the QSFP28 module. All are common within the module and all module voltages are referenced to this potential unless otherwise noted. Connect these directly to the host board signal common ground plane.
- VccRx, Vcc1 and VccTx are the receiving and transmission power suppliers and shall be applied concurrently. Recommended host board power supply filtering is shown in Figure 3 below. Vcc Rx, Vcc1 and Vcc Tx may be internally connected within the module in any combination. The connector pins are each rated for a maximum current of 1000mA.

LWO-QSFP28-LR4-HPE

100Gbit QSFP28 LR4, 10km, DFB, LC-Duplex, SM, Enterprise Version, HP Aruba

Electrical Characteristics

Tested under recommended operating conditions, unless otherwise noted

Parameter	Symbol	Min.	Typical	Max.	Units	Notes
Supply Voltage	V _{cc}	3.13	3.3	3.47	V	
Transmitter						
Input differential impedance	R _{in}		100		Ω	1
Differential data input swing	V _{in, pp}	180		1000	mV	
Transmit Disable Voltage	VD	V _{cc} - 1.3		V _{cc}	V	2
Transmit Enable Voltage	VEN	V _{ee}		V _{ee} + 0.8	V	
Receiver						
Differential data output swing	V _{out, pp}	300		850	mV	3
LOS Fault	VLOS _{fault}	V _{cc} - 1.3		V _{cc} HOST	V	4
LOS Normal	VLOS _{norm}	V _{ee}		V _{ee} +0.8	V	4

Notes

1. Connected directly to TX data input pins. AC coupled thereafter.
2. Optional for TX disable
3. Into 100 ohms differential termination
4. Loss Of Signal is LVTTL. Logic 0 indicates normal operation; logic 1 indicates no signal detected.

Absolute Maximum Ratings

It has to be noted that the operation in excess of any individual absolute maximum ratings might cause permanent damage to this module.

Parameter	Symbol	Min.	Max.	Units	Notes
Storage Temperature	T _s	-40	85	degC	
Operating Case Temperature	T _{OP}	0	70	degC	
Power Supply Voltage	V _{CC}	-0,5	3,6	V	
Relative Humidity (non- condensation)	RH	0	85	%	
Rx Damage Threshold, per Lane	P _{Rdmg}	5,5		dBm	

Recommended Operating Conditions and Power Supply Requirements

Parameter	Symbol	Min.	Typical	Max.	Units
Operating Case Temperature	T _{OP}	0		70	degC
Power Supply Voltage	V _{CC}	3.135	3.3	3.465	V
Data Rate			103.1		Gb/s
Supply Current	I _{CC}			1.2	A

Digital Diagnostic Functions

The following digital diagnostic characteristics are defined over the Recommended Operating Environment unless otherwise specified. It is compliant to SFF-8436.

Parameter	Symbol	Min.	Max.	Units	Notes
Temperature monitor absolute error	DML_Temp	-3	3	degC	Over operating temperature range
Supply voltage monitor absolute error	DML_VCC	-0.15	0.15	V	Over full operating range
Channel RX power monitor absolute error	DML_RX_Ch	-2	2	dB	1
Channel Bias current monitor	DML_Ibias_Ch	-10%	10%	mA	Ch1~Ch4
Channel TX power monitor absolute error	DML_TX_Ch	-2	2	dB	1

Notes

1. Due to measurement accuracy of different single mode fibers, there could be an additional +/-1 dB fluctuation, or a +/-3 dB total accuracy.

LWO-QSFP28-LR4-HPE

100Gbit QSFP28 LR4, 10km, DFB, LC-Duplex, SM, Enterprise Version, HP Aruba

Optical Characteristics

Tested under recommended operating conditions, unless otherwise noted

Parameter	Symbol	Unit	Min.	Typical	Max.	Notes
Transmitter						
Signaling rate, each lane	DR _{PL}	Gb/s	25.78125 ±100 ppm			1
Four Lane Wavelength Range	λ1	nm	1294.53	1295.56	1296.59	
	λ2		1299.02	1300.05	1301.09	
	λ3		1303.54	1304.58	1305.63	
	λ4		1308.09	1309.14	1310.19	
Total launch power	P _{out}	dBm	-	-	10.5	
Average launch power, each lane	P _{avg}	dBm	-4.3	-	4.5	2
Optical modulation amplitude, each lane (OMA)	OMA	dBm	-1.3	-	4.5	
Extinction ratio	ER	dB	4	-	-	
Side-mode suppression ratio	SMSR	dB	30	-	-	
Average launch power of OFF transmitter, per lane	P _{OFF}	dBm	-	-	-30	
Relative Intensity Noise	RIN	dB/Hz		-	-130	
Optical return loss tolerance	ORLT	dB	-	-	20	
Transmitter reflectance	TR	dB	-	-	-12	
Transmitter eye mask {X1, X2, X3, Y1, Y2, Y3}	Mt		{0.25, 0.4, 0.45, 0.25, 0.28, 0.4}			3
Receiver						
Receive Rate for Each Lane	DR _{PL}	Gb/s	25.78125 ±100 ppm			4
Four Lane Wavelength Range	λ1	nm	1294.53	1295.56	1296.59	
	λ2		1299.02	1300.05	1301.09	
	λ3		1303.54	1304.58	1305.63	
	λ4		1308.09	1309.14	1310.19	
Overload Input Optical Power	P _{max}	dBm	5.5	-	-	
Average Receive Power for Each Lane	P _{in}	dBm	-10.6	-	4.5	
Receiver sensitivity (OMA), each lane	P _{sens}	dBm	-	-	-8.6	5
Return Loss	RL	dB	-26	-	-	
Los De-Assert	P _d	dBm	-	-	-11.6	
Los Assert	P _a	dBm	-23.6	-	-	
Loss Hysteresis	P _d -P _a	dBm	0.5	-	6	

Notes

1. Transmitter consists of 4 lasers operating at 25.78Gb/s each.
2. Minimum value is informative.
3. Hit ratio 5x10⁻⁵.
4. Receiver consists of 4 photodetectors operating at 25.78Gb/s each.
5. Measured with a PRBS 2³¹-1 test pattern, @25.78Gb/s

LWO-QSFP28-LR4-HPE

100Gbit QSFP28 LR4, 10km, DFB, LC-Duplex, SM, Enterprise Version, HP Aruba

Mechanical Dimensions

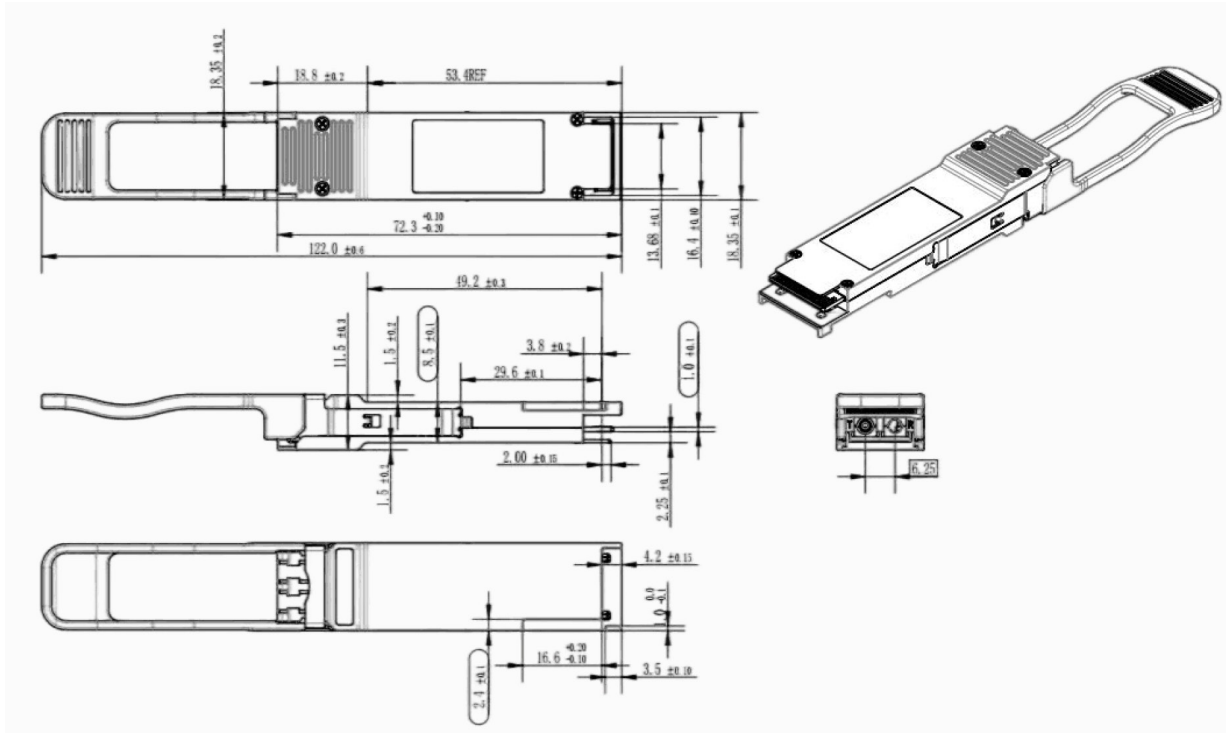

Figure 4. Mechanical Outline

ESD

This transceiver is specified as ESD threshold 1kV for high speed data pins and 2kV for all other electrical input pins, tested per MIL-STD-883, Method 3015.4 / JESD22- A114-A (HBM). However, normal ESD precautions are still required during the handling of this module. This transceiver is shipped in ESD protective packaging. It should be removed from the packaging and handled only in an ESD protected environment.

Laser Safety

This is a Class 1 Laser Product according to EN 60825-1:2014. This product complies with 21 CFR 1040.10 and 1040.11 except for deviations pursuant to Laser Notice No. 50, dated (June 24, 2007).

Caution: Use of controls or adjustments or performance of procedures other than those specified herein may result in hazardous radiation exposure.