

LWO-QSFP-LX4

40 Gbit QSFP+ LX4, 2km SM/150m MM, DFP, LC-Duplex, Enterprise Version

Features

- 4 CWDM lanes MUX/DEMUX design
- Up to 11.2Gb/s data rate per wavelength
- QSFP+ MSA compliant
- IEEE 802.3ba Electrical Interface
- Digital diagnostic capabilities
- Compliant with QDR/DDR InfiniBand data rates
- Up to 150m transmission on OM3 multimode fiber (MMF) or 2km transmission on single mode fiber (SMF)
- Operating case temperature: 0 to 70°C
- Maximum power consumption 3.5W
- LC duplex connector

Application

- 40GBASE-LX4 Ethernet Links
- InfiniBand QDR and DDR interconnects
- Client-side 40G datacom connections



General Description

This product is a transceiver module designed for optical transmission applications over both MMF and SMF with transmission distances of up to 150m on MMF (OM3) and 2km on SMF. The module converts 4 inputs channels (ch) of 10Gb/s electrical data to 4 CWDM optical signals, and multiplexes them into a single channel for 40Gb/s optical transmission. Reversely, on the receiver side, the module optically de-multiplexes a 40Gb/s input into 4 CWDM channels signals, and converts them to 4 channel output electrical data.

The central wavelengths of the 4 CWDM channels are 1271, 1291, 1311 and 1331 nm as members of the CWDM wavelength grid defined in ITU-T G.694.2. It contains a duplex LC connector for the optical interface and a 148-pin connector for the electrical interface.

The product is designed with form factor, optical/electrical connection and digital diagnostic interface according to the QSFP+ Multi-Source Agreement (MSA). It has been designed to meet the harshest external operating conditions including temperature, humidity and EMI interference.

For applications over OM3/OM4 MMF, MMF cables are directly connected to the LC connectors of QSFP+ LX4 module and optical signal is directly launched from the transmitter into the MMF cable as shown in Figure 1. For applications over SMF, the module is used as a QSFP+ IR4 module and SMF cables are directly connected to the LC connectors of the module as shown in Figure 2.

Transceiver Block Diagram 1/2

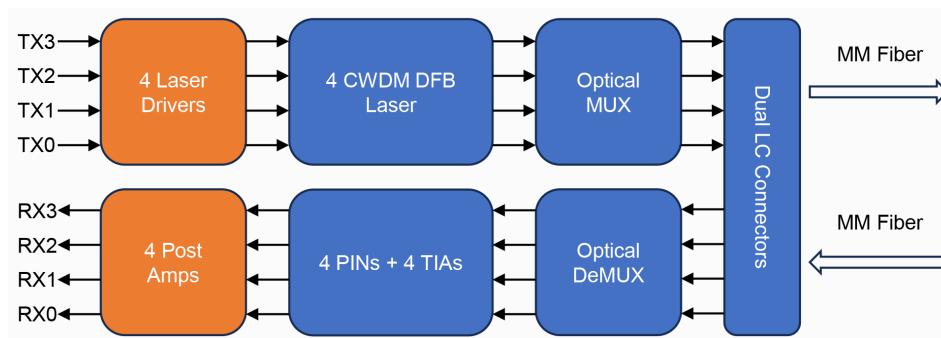

Figure 1. Transceiver Block Diagram for Applications over Multimode Fiber

LWO-QSFP-LX4

40 Gbit QSFP+ LX4, 2km SM/150m MM, DFP, LC-Duplex, Enterprise Version

Transceiver Block Diagram 2/2

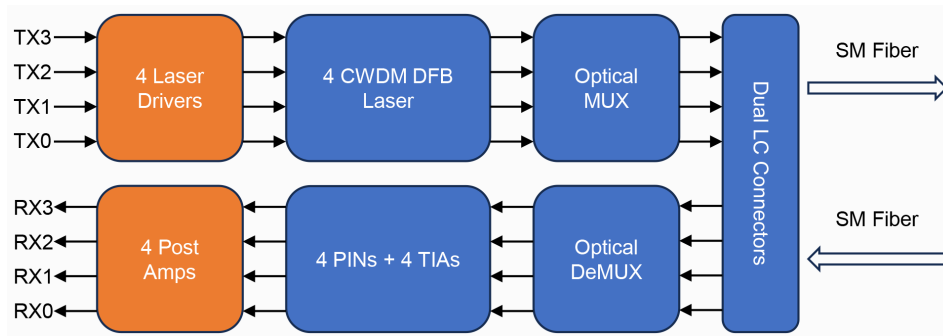

Figure 2. Transceiver Block Diagram for Applications over Single Mode Fiber

Pin Assignment and Description

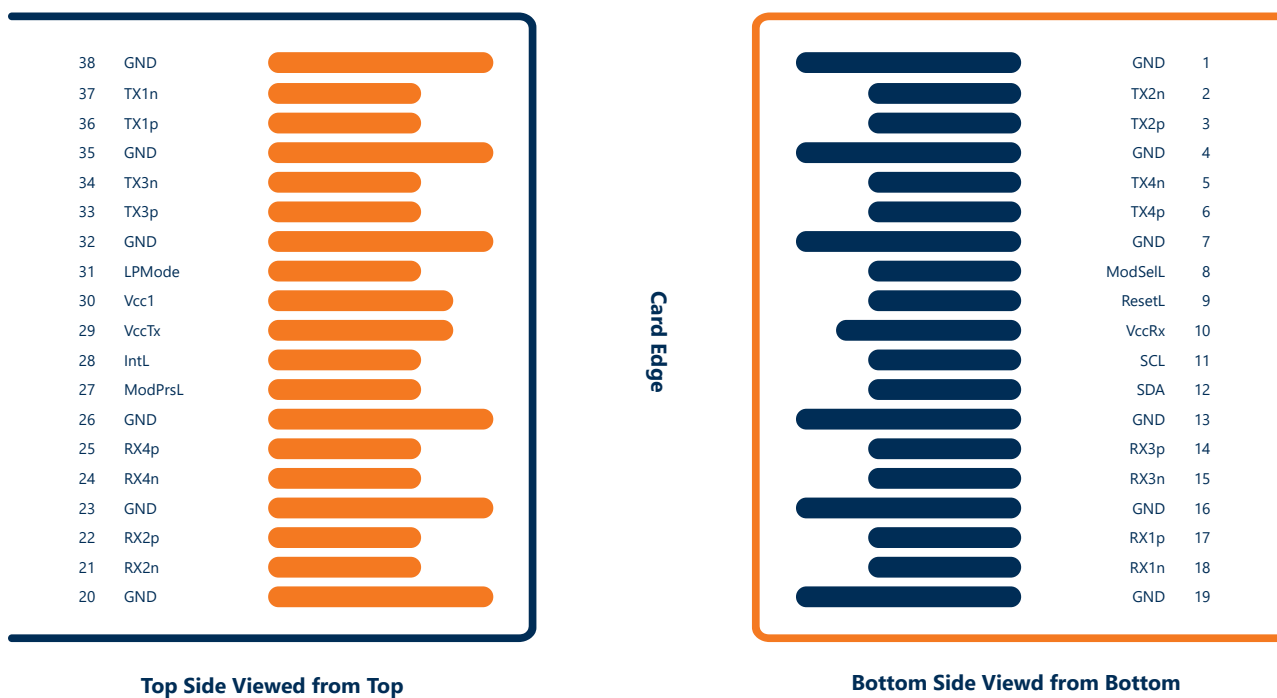

Figure 3. MSA Compliant Connector

LWO-QSFP-LX4

40 Gbit QSFP+ LX4, 2km SM/150m MM, DFP, LC-Duplex, Enterprise Version

PIN Definition 1/2

PIN	Logic	Symbol	Name/Description	Notes
1		GND	Ground	1
2	CML-I	Tx2n	Transmitter Inverted Data Input	
3	CML-I	Tx2p	Transmitter Non-Inverted Data output	
4		GND	Ground	1
5	CML-I	Tx4n	Transmitter Inverted Data Input	
6	CML-I	Tx4p	Transmitter Non-Inverted Data output	
7		GND	Ground	1
8	LVTTL-I	ModSelL	Module Select	
9	LVTTL-I	ResetL	Module Reset	
10		VccRx	+3.3V Power Supply Receiver	2
11	LVC MOS-I/O	SCL	2-Wire Serial Interface Clock	
12	LVC MOS-I/O	SDA	2-Wire Serial Interface Data	
13		GND	Ground	
14	CML-O	Rx3p	Receiver Non-Inverted Data Output	
15	CML-O	Rx3n	Receiver Inverted Data Output	
16		GND	Ground	1
17	CML-O	Rx1p	Receiver Non-Inverted Data Output	
18	CML-O	Rx1n	Receiver Inverted Data Output	
19		GND	Ground	1
20		GND	Ground	1
21	CML-O	Rx2n	Receiver Inverted Data Output	
22	CML-O	Rx2p	Receiver Non-Inverted Data Output	
23		GND	Ground	1
24	CML-O	Rx4n	Receiver Inverted Data Output	1
25	CML-O	Rx4p	Receiver Non-Inverted Data Output	
26		GND	Ground	1
27	LVTTL-O	ModPrsL	Module Present	
28	LVTTL-O	IntL	Interrupt	
29		VccTx	+3.3 V Power Supply transmitter	2
30		Vcc1	+3.3 V Power Supply	2
31	LVTTL-I	LPMODE	Low Power Mode	
32		GND	Ground	1
33	CML-I	Tx3p	Transmitter Non-Inverted Data Input	
34	CML-I	Tx3n	Transmitter Inverted Data Output	
35		GND	Ground	1
36	CML-I	Tx1p	Transmitter Non-Inverted Data Input	
37	CML-I	Tx1n	Transmitter Inverted Data Output	
38		GND	Ground	1

LWO-QSFP-LX4

40 Gbit QSFP+ LX4, 2km SM/150m MM, DFP, LC-Duplex, Enterprise Version

Notes

1. GND is the symbol for signal and supply (power) common for the QSFP28 module. All are common within the module and all module voltages are referenced to this potential unless otherwise noted. Connect these directly to the host board signal common ground plane.
2. VccRx, Vcc1 and VccTx are the receiving and transmission power suppliers and shall be applied concurrently. Recommended host board power supply filtering is shown in Figure 3 below. Vcc Rx, Vcc1 and Vcc Tx may be internally connected within the module in any combination. The connector pins are each rated for a maximum current of 500mA.

Recommended Power Supply Filter

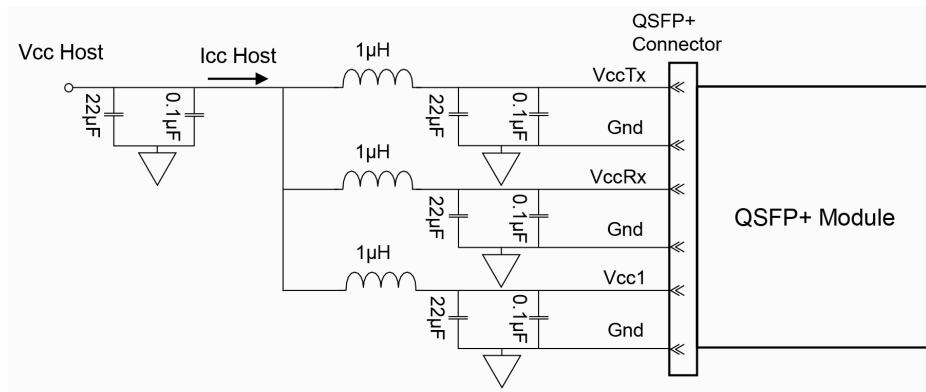

Figure 4. Recommended Power Supply Filter

Absolute Maximum Ratings

The operation in excess of any absolute maximum ratings might cause permanent damage to this module.

Parameter	Symbol	Min	Max	Units	Note
Storage Temperature	T_s	-40	85	degC	
Operating Case Temperature	T_{OP}	0	70	degC	
Power Supply Voltage	V_{CC}	-0.3	3.6	V	
Relative Humidity (non-condensation)	RH	0	85	%	
Damage Threshold	TH_d	3.3		dBm	

Recommended Operating Conditions and Power Supply Requirements

Parameter	Symbol	Min	Typical	Max	Units
Operating Case Temperature	T_{OP}	0		70	degC
Power Supply Voltage	V_{CC}	3.135	3.3	3.465	V
Data Rate, each Lane			10.3125	11.2	Gb/s
Control Input Voltage High		2		V_{CC}	V
Control Input Voltage Low		0		0.8	V
Link Distance (OM3 MMF)	D1			150	m
Link Distance (SMF)	D2			2	km

LWO-QSFP-LX4

40 Gbit QSFP+ LX4, 2km SM/150m MM, DFP, LC-Duplex, Enterprise Version

Electrical Characteristics

The following electrical characteristics are defined over the Recommended Operating Environment unless otherwise specified.

Parameter	Symbol	Min.	Typical	Max.	Units	Notes
Power Consumption				3.5	W	
Supply Current	I_{cc}			1.07	A	
Transceiver Power-on Initialization Time				2000	ms	1
Transmitter (each Lane)						
Single-ended Input Voltage Tolerance (Note 2)		-0.3		4	V	Referred to TP1 signal common
AC Common Mode Input Voltage Tolerance		15			mV	RMS
Differential Input Voltage Swing Threshold		50			mVpp	LOSA Threshold
Differential Input Voltage Swing	$V_{in,pp}$	190		700	mVpp	
Differential Input Impedance	Z_{in}	90	100	110	Ohm	
Differential Input Return Loss		See IEEE 802.3ba 86A.4.11			dB	10MHz-11.1GHz
J2 Jitter Tolerance	J_{t2}	0.17			UI	
J9 Jitter Tolerance	J_{t9}	0.29			UI	
Data Dependent Pulse Width Shrinkage (DDPWS) Tolerance		0.07			UI	
Eye Mask Coordinates {X1, X2, Y1, Y2}		0.11, 0.31 95, 350			UI mV	Hit Ratio = 5×10^{-5}
Receiver (per Lane)						
Single-ended Output Voltage		-0.3		4	V	Referred to signal common
AC Common Mode Output Voltage				7.5	mV	RMS
Differential Output Voltage Swing	$V_{out,pp}$	300		850	mVpp	
Differential Output Impedance	Z_{out}	90	100	110	Ohm	
Termination Mismatch at 1MHz				5	%	
Differential Output Return Loss		See IEEE 802.3ba 86A.4.2.1			dB	10MHz-11.1GHz
Common Mode Output Return Loss		See IEEE 802.3ba 86A.4.2.2			dB	10MHz-11.1GHz
Output Transition Time		28			ps	20% to 80%
J2 Jitter output	J_{o2}			0.42	UI	
J9 Jitter output	J_{o9}			0.65	UI	
Eye Mask Coordinates {X1, X2, Y1, Y2}			0.29, 0.5 150, 425		UI mV	Hit Ratio = 5×10^{-5}

Notes

- Power-on initialization time is the time from when the power supply voltages reach and remain above the minimum recommended operating supply voltages to the time when the module is fully functional.
- The single ended input voltage tolerance is the allowable range of the instantaneous input signals.

LWO-QSFP-LX4

40 Gbit QSFP+ LX4, 2km SM/150m MM, DFP, LC-Duplex, Enterprise Version

Optical Characteristics

Parameter	Symbol	Min	Typ	Max	Unit	Notes
Lane Wavelength	L0	1264.5	1271	1277.5	nm	
	L1	1284.5	1291	1297.5		
	L2	1304.5	1311	1317.5		
	L3	1324.5	1331	1337.5		
Transmitter						
Total Average Launch Power (for SMF)	$P_{T,SMF}$			8.3	dBm	
Total Average Launch Power (for MMF)	$P_{T,MMF}$			9.5	dBm	
Average Launch Power, each Lane (for SMF)	$P_{AVG,SMF}$	-7		2.3	dBm	
Average Launch Power, each Lane (for MMF)	$P_{AVG,MMF}$	-5		3.5	dBm	
OMA, each Lane (for SMF)	$P_{OMA,SMF}$	-6		3.5	dBm	1
OMA, each Lane (for MMF)	$P_{OMA,MMF}$	-4		4.5	dBm	
Difference in Launch Power between any Two Lanes (OMA)	Ptx, diff			6.5	dB	
Launch Power in OMA minus Transmitter and Dispersion Penalty (TDP), each Lane		-6.8			dBm	
TDP, each Lane	TDP			2.6	dB	
Extinction Ratio	ER	3.5			dB	
Relative Intensity Noise	RIN			-128	dB/Hz	12dB reflection
Transmitter Reflectance	R_T			-12	dB	
Transmitter Eye Mask Definition {X1, X2, X3, Y1, Y2, Y3}			{0.23, 0.34, 0.43, 0.27, 0.35, 0.4}			
Average Launch Power OFF Transmitter, each Lane	Poff			-30	dBm	
Receiver						
Damage Threshold, each Lane	TH_d	4.5			dBm	2
Total Average Receive Power (for SMF)				8.3	dBm	
Total Average Receive Power (for MMF)				9.5	dBm	
Average Receive Power, each Lane (for SMF)		-11.7		2.3	dBm	
Average Receive Power, each Lane (for MMF)		-7		3.5	dBm	
Receiver Reflectance	R_R			-26	dB	
Receive Power (OMA), each Lane (for SMF)				3.5	dBm	
Receive Power (OMA), each Lane (for MMF)				4.5	dBm	
Receiver Sensitivity (OMA), each Lane (for SMF)	SEN_{SMF}			-11.5	dBm	
Receiver Sensitivity (OMA), each Lane (for MMF)	SEN_{MMF}			-10.5	dBm	
Difference in Receive Power between any Two Lanes (OMA)	Prx, diff			7.5	dB	
LOS Assert	LOSA	-28			dBm	
LOS Deassert	LOSD			-15	dBm	
LOS Hysteresis		0.5			dB	
Receiver Electrical 3 dB upper Cutoff Frequency, each Lane	F_c			12.3	GHz	

Notes

- Even if the TDP < 0.8 dB, the OMA min must exceed the minimum value specified here.
- The receiver shall be able to tolerate, without damage, continuous exposure to a modulated optical input signal having this power level on one lane. The receiver does not have to operate correctly at this input power.

LWO-QSFP-LX4

40 Gbit QSFP+ LX4, 2km SM/150m MM, DFP, LC-Duplex, Enterprise Version

Digital Diagnostic Functions

The following digital diagnostic characteristics are defined over the normal operating conditions unless otherwise specified.

Parameter	Symbol	Min.	Max.	Units	Notes
Temperature monitor absolute error	DMI_Temp	-3	3	degC	Over operating temperature
Supply voltage monitor absolute error	DMI_VCC	-0.1	0.1	V	Full operating range
Channel RX power monitor absolute error	DMI_RX	-3	3	dB	Per channel
Channel Bias current monitor	DMI_Ibias	-10%	10%	mA	Per channel
Channel TX power monitor absolute error	DMI_TX	-3	3	dB	Per channel

Mechanical Dimensions

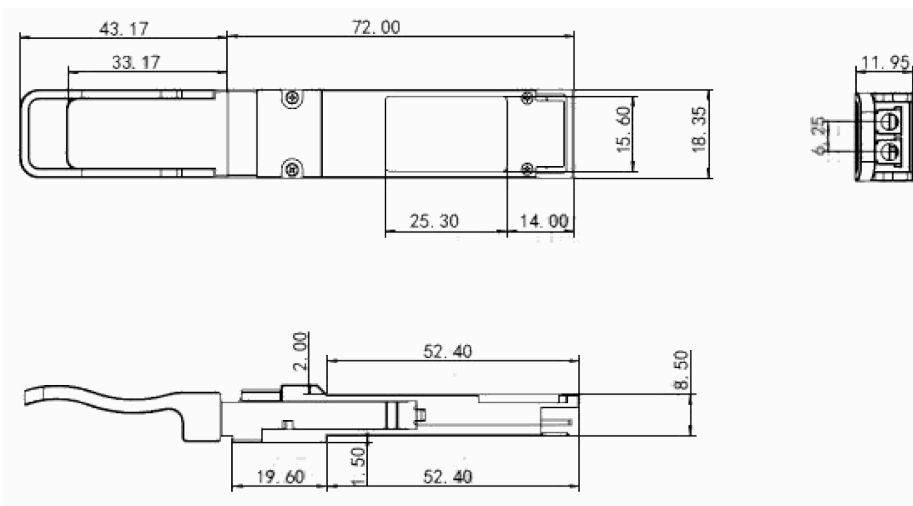

Figure 5. Mechanical Outline

ESD

This transceiver is specified as ESD threshold 1kV for SFI pins and 2kV for all other electrical input pins, tested per MIL-STD-883, Method 3015.4 /JESD22-A114-A (HBM). However, normal ESD precautions are still required during the handling of this module. This transceiver is shipped in ESD protective packaging. It should be removed from the packaging and handled only in an ESD protected environment.

Laser Safety

This is a Class 1 Laser Product according to EN 60825-1:2014. This product complies with 21 CFR 1040.10 and 1040.11 except for deviations pursuant to Laser Notice No. 50, dated (June 24, 2007).

Caution: Use of controls or adjustments or performance of procedures other than those specified herein may result in hazardous radiation exposure.