

19" SINGLE WALLMOUNT CABINET, PRO 2nd GENERATION

WCAB PS2 600X600 (B)

DESCRIPTION

- Wirewin® 19" single section Wallmount Cabinet
- Glasdoor, lockable
- detachable Side Panels with special hidden spring loaded pin system
- 2 pairs 19" mounting Rails, Front Rails are adjustable, Rear Rails are fixed
- 600 mm width
- 600 mm depth, 450 mm available
- 4U / 6U / 9U / 12U / 15U / 18U / 21U heights
- tested with 100 kg load

Specifications:

Material:	<ul style="list-style-type: none"> • Main Body (Structure): DIN EN 10130-DC-01-6112 CRS, 0,8 mm • Front Door: EN 12150-1 Tempered Secure Glas, 4,0 mm • 19" Equipment Mounting Rails: DIN EN 10130-DC-01-6112 CRS, 1,2 mm • Rear Body Frame: DIN EN 10130-DC-01-6112 CRS, 1,0 mm • Side Panels: DIN EN 10130-DC-01-6112 CRS, 0,8 mm
Colour:	<ul style="list-style-type: none"> • RAL7035, Light Grey or RAL9005 Black
max. Load:	<ul style="list-style-type: none"> • 100 kg load tested
Packaging:	<ul style="list-style-type: none"> • single, carton packaging, assembled

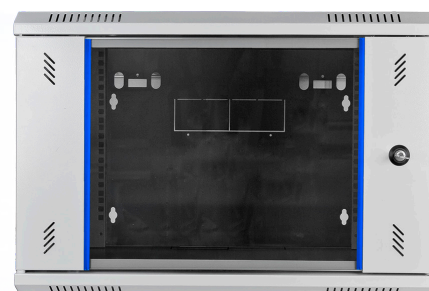
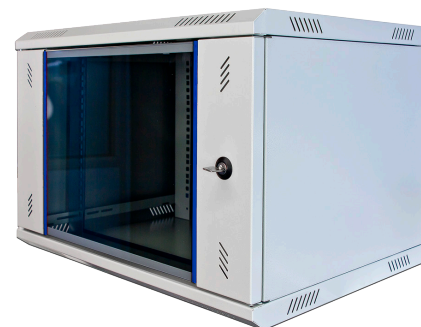

COLOR: RAL7035, LIGHT GREY

UNITS	PART NUMBER	WIDTH	DEPTH	HEIGHT	WEIGHT	EAN NUMBER	P-WEIGHT	PACKING BOX SIZE
4U	WCAB PS2 600X600X4U	600	600	278	13,4 kg	9120072487354	15,8 kg	635 x 655 x 292
6U	WCAB PS2 600X600X6U	600	600	367	15,4 kg	9120072487361	17,8 kg	635 x 655 x 382
9U	WCAB PS2 600X600X9U	600	600	500	18,0 kg	9120072487385	20,4 kg	635 x 655 x 514
12U	WCAB PS2 600X600X12U	600	600	633	21,8 kg	9120072487408	24,5 kg	635 x 655 x 677
15U	WCAB PS2 600X600X15U	600	600	767	26,2 kg	9120072487422	28,9 kg	635 x 655 x 791
18U	WCAB PS2 600X600X18U	600	600	900	27,6 kg	9120072487446	30,3 kg	635 x 655 x 914
21U	WCAB PS2 600X600X21U	600	600	1033	30,6 kg	9120072487460	33,6 kg	635 x 655 x 1047

COLOR: RAL9005, BLACK

UNITS	PART NUMBER	WIDTH	DEPTH	HEIGHT	WEIGHT	EAN NUMBER	P-WEIGHT	PACKING BOX SIZE
4U	WCAB PS2 600X600X4U B	600	600	278	13,4 kg	9120072487484	15,8 kg	635 x 655 x 292
6U	WCAB PS2 600X600X6U B	600	600	367	15,4 kg	9120072487491	17,8 kg	635 x 655 x 382
9U	WCAB PS2 600X600X9U B	600	600	500	18,0 kg	9120072487507	20,4 kg	635 x 655 x 514
12U	WCAB PS2 600X600X12U B	600	600	633	21,8 kg	9120072487521	24,5 kg	635 x 655 x 677
15U	WCAB PS2 600X600X15U B	600	600	767	26,2 kg	9120072487545	28,9 kg	635 x 655 x 791
18U	WCAB PS2 600X600X18U B	600	600	900	27,6 kg	9120072487552	30,3 kg	635 x 655 x 914
21U	WCAB PS2 600X600X21U B	600	600	1033	30,6 kg	9120072487576	33,6 kg	635 x 655 x 1047

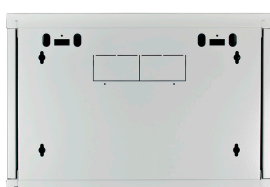
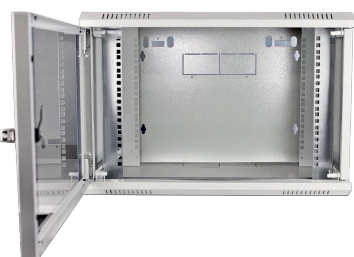

19" SINGLE WALLMOUNT CABINET, PRO 2nd GENERATION

WCAB PS2 600X600 (B)

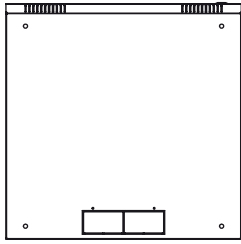

BOTTOM VIEW

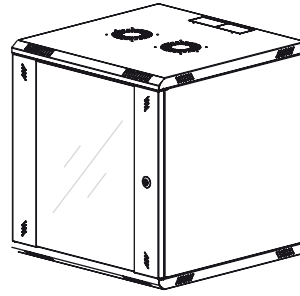

ISOMETRIC VIEW

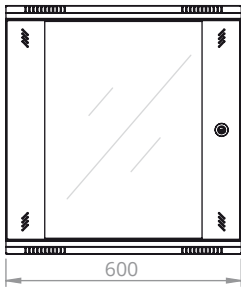

FRONT VIEW

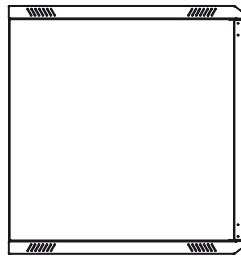

SIDE VIEW

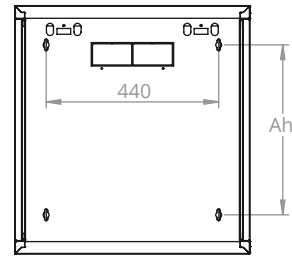

REAR VIEW

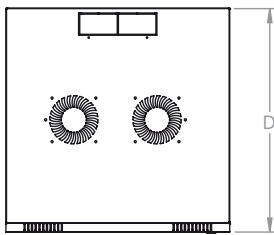

TOP VIEW

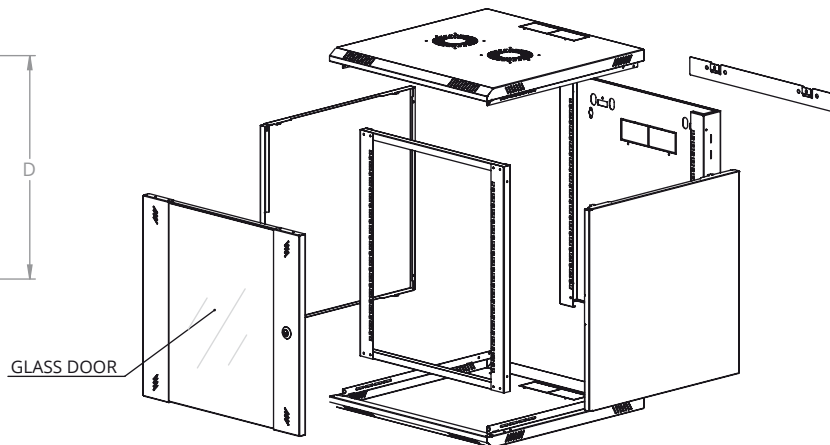

EXPLODED VIEW

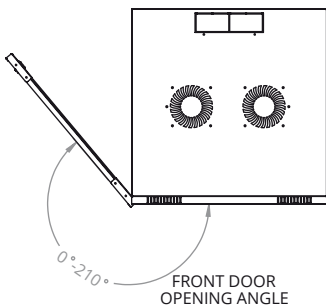

FRONT DOOR
OPENING ANGLE

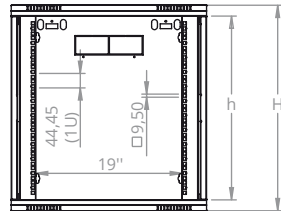

DIMENSIS IN
WITDH AND HEIGHT

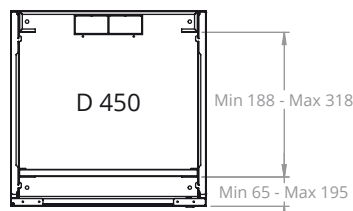

MAX/ MIN EQUIPMENT
MOUNTING DISTANCE
(450)

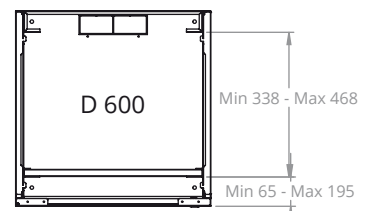

MAX/ MIN EQUIPMENT
MOUNTING DISTANCE
(600)

UNITS	Ah	h	H	D
4U	78	210	278	600 / 450
6U	167	299	367	600 / 450
9U	301	432	500	600 / 450
12U	434	565	633	600 / 450
15U	567	698	766	600 / 450
18U	700	832	900	600 / 450
21U	834	934	1033	600 / 450