

19" SINGLE WALLMOUNT CABINET, PRO 2nd GENERATION

WCAB PS2 600X450 (B)

DESCRIPTION

- Wirewin® 19" single section Wallmount Cabinet
- Glasdoor, lockable
- detachable Side Panels with special hidden spring loaded pin system
- 2 pairs 19" mounting Rails, Front Rails are adjustable, Rear Rails are fixed
- 600 mm width
- 450 mm depth, 600 mm available
- 4U / 6U / 9U / 12U / 15U / 18U / 21U heights
- tested with 100 kg load

Specifications:

Material:	<ul style="list-style-type: none"> • Main Body (Structure): DIN EN 10130-DC-01-6112 CRS, 0,8 mm • Front Door: EN 12150-1 Tempered Secure Glas, 4,0 mm • 19" Equipment Mounting Rails: DIN EN 10130-DC-01-6112 CRS, 1,2 mm • Rear Body Frame: DIN EN 10130-DC-01-6112 CRS, 1,0 mm • Side Panels: DIN EN 10130-DC-01-6112 CRS, 0,8 mm
Colour:	<ul style="list-style-type: none"> • RAL7035, Light Grey or RAL9005 Black
max. Load:	<ul style="list-style-type: none"> • 100 kg load tested
Packaging:	<ul style="list-style-type: none"> • single, carton packaging, assembled

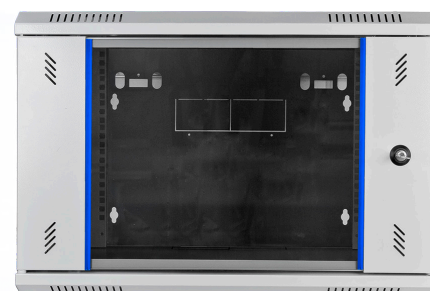

COLOR: RAL7035, LIGHT GREY

UNITS	PART NUMBER	WIDTH	DEPTH	HEIGHT	WEIGHT	EAN NUMBER	P-WEIGHT	PACKING BOX SIZE
4U	WCAB PS2 600X450X4U	600	450	278	11,4 kg	9120072487286	13,4 kg	645 x 515 x 292
6U	WCAB PS2 600X450X6U	600	450	367	13,0 kg	9120072487293	15,0 kg	645 x 515 x 382
9U	WCAB PS2 600X450X9U	600	450	500	15,8 kg	9120072487309	17,8 kg	645 x 515 x 514
12U	WCAB PS2 600X450X12U	600	450	633	18,8 kg	9120072487316	21,1 kg	645 x 515 x 677
15U	WCAB PS2 600X450X15U	600	450	767	21,6 kg	9120072487323	24,1 kg	645 x 515 x 791
18U	WCAB PS2 600X450X18U	600	450	900	24,2 kg	9120072487330	26,7 kg	645 x 515 x 914
21U	WCAB PS2 600X450X21U	600	450	1033	26,8 kg	9120072487347	29,8 kg	645 x 515 x 1047

COLOR: RAL9005, BLACK

UNITS	PART NUMBER	WIDTH	DEPTH	HEIGHT	WEIGHT	EAN NUMBER	P-WEIGHT	PACKING BOX SIZE
4U	WCAB PS2 600X450X4U B	600	450	278	11,4 kg	9120072487378	13,4 kg	645 x 515 x 292
6U	WCAB PS2 600X450X6U B	600	450	367	13,0 kg	9120072487392	15,0 kg	645 x 515 x 382
9U	WCAB PS2 600X450X9U B	600	450	500	15,8 kg	9120072487415	17,8 kg	645 x 515 x 514
12U	WCAB PS2 600X450X12U B	600	450	633	18,8 kg	9120072487439	21,1 kg	645 x 515 x 677
15U	WCAB PS2 600X450X15U B	600	450	767	21,6 kg	9120072487453	24,1 kg	645 x 515 x 791
18U	WCAB PS2 600X450X18U B	600	450	900	24,2 kg	9120072487477	26,7 kg	645 x 515 x 914
21U	WCAB PS2 600X450X21U B	600	450	1033	26,8 kg	9120072487491	29,8 kg	645 x 515 x 1047

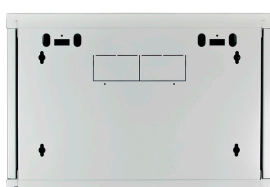
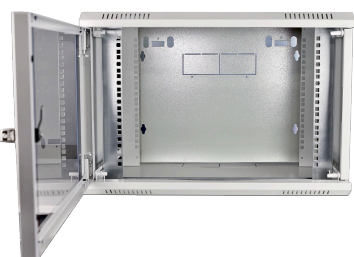

19" SINGLE WALLMOUNT CABINET, PRO 2nd GENERATION

WCAB PS2 600X450 (B)

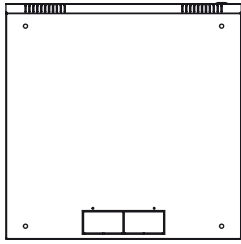

BOTTOM VIEW

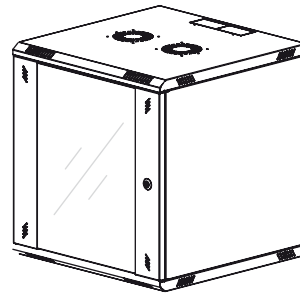

ISOMETRIC VIEW

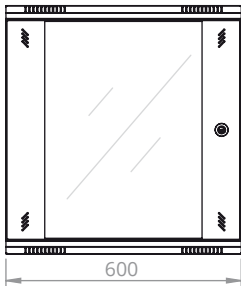

FRONT VIEW

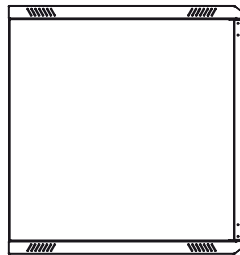

SIDE VIEW

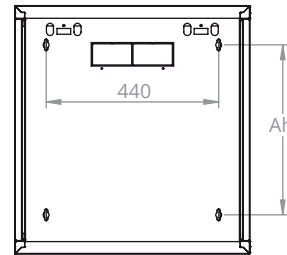

REAR VIEW

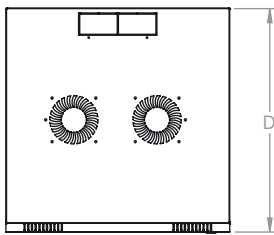

TOP VIEW

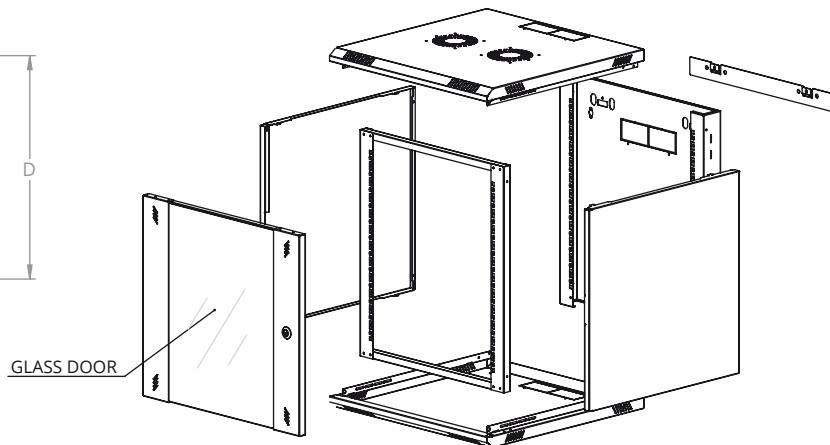

EXPLODED VIEW

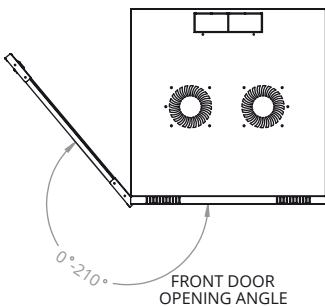

FRONT DOOR
OPENING ANGLE

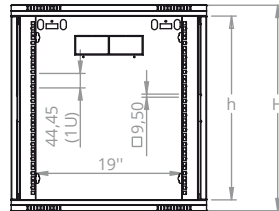

DIMENSIS IN
WITDH AND HEIGHT

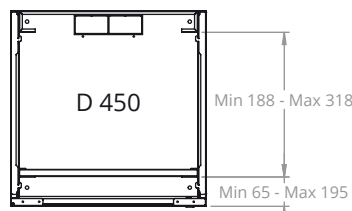

MAX/ MIN EQUIPMENT
MOUNTING DISTANCE
(450)

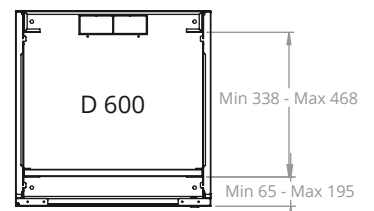

MAX/ MIN EQUIPMENT
MOUNTING DISTANCE
(600)

UNITS	Ah	h	H	D
4U	78	210	278	600 / 450
6U	167	299	367	600 / 450
9U	301	432	500	600 / 450
12U	434	565	633	600 / 450
15U	567	698	766	600 / 450
18U	700	832	900	600 / 450
21U	834	934	1033	600 / 450